



ctesi

Soluções técnicas

Soluciones técnicas
Technical solutions
Solutions techniques

2026



A CTESI Technic reúne as soluções técnicas para o espaço de banho. A nossa abordagem combina experiência industrial, tecnologia e elevados padrões de qualidade, respondendo às necessidades reais dos profissionais. Todos os produtos cumprem as normas do Espaço Económico Europeu e são concebidos para garantir segurança, fiabilidade e desempenho técnico consistente e duradouro.



CTESI Technic reúne las soluciones técnicas para el espacio de baño. Nuestro enfoque combina experiencia industrial, tecnología y altos estándares de calidad, respondiendo a las necesidades reales de los profesionales. Todos los productos cumplen con las normas del Espacio Económico Europeo y están diseñados para garantizar seguridad, fiabilidad y un rendimiento técnico consistente y duradero.



CTESI Technic brings together technical solutions for the bathroom space. Our approach combines industrial expertise, technology, and high-quality standards, addressing the real needs of professionals. All products comply with European Economic Area (EEA) standards and are designed to ensure safety, reliability, and consistent, long-lasting technical performance.



CTESI Technic réunit les solutions techniques pour l'espace de bain. Notre approche combine expérience industrielle, technologie et normes de qualité élevées, répondant aux besoins réels des professionnels. Tous les produits respectent les normes de l'Espace Économique Européen et sont conçus pour garantir sécurité, fiabilité et performance technique constante et durable.



1 PRODUTOS TÉCNICOS • PRODUCTOS TÉCNICOS
TECHNICAL PRODUCTS • PRODUITS TECHNIQUES

autoclismos
cisternas
concealed
réservoirs

04



46

mecanismos
mecanismos
mechanisms
mécanismes

tubos extensíveis
manguitos flexibles
flexible tubes
tubes extensibles

54



58

excêntricos e tubos de sanita
excéntricos y manguitos inodoro
toilet eccentric and connectors
raccord excentré et connecteurs

calhas e sifões
canaletas y sifones
Shower drains and siphons
caniveaux de douche et siphons

65



87

válvulas de duche
válvula de ducha
shower waste
vidage de douche

2 SIFÕES SIMPLES • SIFONES SIMPLE
SIMPLE SIPHONS • SIPHONS SIMPLES



92

sifões lava-louça
sifones fregadero
dishwasher siphons
siphons lave-vaisselle



97

acessórios máquina de lavar
accesorios para lavadora
washing machine accessories
accessoires machine à laver

3 TAMPOS DE SANITA • TAPAS DE INODORO
TOILET SEATS • ABATTANTS WC

polipropileno
polipropileno
polypropylene
polypropylène

duroplast

mdf

102



104



107



4 ACESSÓRIOS • ACCESORIOS
ACCESSORIES • ACCESSOIRES

válvulas de lavatório
válvulas de lavabo
washbasin waste valves
Boundes pour lavabo

112



116

sifões de lavatório
sifones de lavabo
washbasins traps
siphons de lavabo

torneiras esquadria
válvulas de escuadra
angle valves
robinets d'équerre

120



122

perlatores
aireadores
aerators
aérateur

acessórios torneiras
accesorios grifos
Tap accessories
accessoires de robinetterie

125



Compromisso com a Fiabilidade e a Eficiência Hídrica

Os autoclismos e acessórios CTESI cumprem rigorosamente as mais exigentes normas e diretrizes internacionais, assegurando desempenho técnico superior, eficiência hídrica e fiabilidade operacional.

Compromiso con la fiabilidad y la eficiencia hídrica

Las cisternas y accesorios de lavado de CTESI cumplen estrictamente con los estándares y directrices internacionales más exigentes, garantizando un rendimiento técnico superior, eficiencia hídrica y fiabilidad operativa.

Commitment to reliability and water efficiency

CTESI flush cisterns and accessories strictly comply with the most demanding international standards and guidelines, ensuring superior technical performance, water efficiency and operational reliability.

Engagement en faveur de la fiabilité et de l'efficacité hydrique

Les chasses d'eau et accessoires CTESI respectent rigoureusement les normes et directives internationales les plus exigeantes, garantissant des performances techniques supérieures, une efficacité hydrique optimale et une fiabilité opérationnelle élevée.



Tecnología de Dupla Descarga

Sistema integrado de válvula e placa de comando com configurações 6/3 litros e 4/2 litros, otimizando o consumo de água.

Tecnología de doble descarga

Sistema integrado de válvulas y placa de control con configuraciones de 6/3 litros y 4/2 litros, optimizando el consumo de agua.

Dual Flush Technology

Integrated valve and flush plate system with 6/3 litre and 4/2 litre configurations, optimising water consumption.

Technologie de double chasse

Système intégré de vanne et de plaque de commande avec configurations 6/3 litres et 4/2 litres, optimisant la consommation d'eau.



Normas Europeias

Cumprimento das normas EN 14055 (Autoclismos), EN 14124 (Torneiras de Bóia), EN 274 (Válvulas de Duche), EN 1253 (Calhas de Duche) e EN 997 (Válvulas de Descarga).

Normas Europeas

Cumplimiento de las normas EN 14055 (Inodoros con descarga), EN 14124 (grifos flotantes), EN 274 (válvulas de ducha), EN 1253 (barandillas de ducha) y EN 997 (válvulas de descarga).

European Standards

Compliance with EN 14055 (Flush Cisterns), EN 14124 (Float Valves), EN 274 (Shower Waste Traps), EN 1253 (Shower Channels) and EN 997 (Flush Valves).

Normes européennes

Conformité aux normes EN 14055 (Chasses d'eau), EN 14124 (Robinets à flotteur), EN 274 (Siphons de douche), EN 1253 (Caniveaux de douche) et EN 997 (Mécanismes de chasse).



Certificação ANQIP

Atesta a eficiência hídrica dos autoclismos CTESI.

Certificación ANQIP

Atestigua la eficiencia hídrica de las cisternas CTESI.

ANQIP Certification

Certifies the water efficiency of CTESI flush cisterns

Certification ANQIP

Atteste de l'efficacité hydrique des chasses d'eau CTESI.



Certificação C.E.

Conformidade com requisitos de segurança, saúde e protecção ambiental da UE.

Certificación C.E.

Cumplimiento de los requisitos de seguridad, salud y protección ambiental de la UE.

CE Certification

Compliance with EU safety, health and environmental protection requirements.

Certification CE

Conformité aux exigences de sécurité, de santé et de protection de l'environnement de l'UE.



Certificação SASO 1257:2017

Conformidade com as normas sauditas de segurança e qualidade.

Certificación SASO 1257:2017

Cumplimiento de los estándares de seguridad y calidad saudies.

SASO 1257:2017 Certification

Compliance with Saudi safety and quality standards.

Certification SASO 1257:2017

Conformité aux normes saoudiennes de sécurité et de qualité.



ISO 9001:2015

Certificação em Sistemas de Gestão da Qualidade.

ISO 9001:2015

Certificación en Sistemas de Gestión de la Calidad.

ISO 9001:2015

Quality Management System Certification.

ISO 9001:2015

Certification du système de management de la qualité.

Iconografia

Iconografía
Iconography
Iconographie



EFICIÊNCIA HÍDRICA
EFICIENCIA HÍDRICA
WATER EFFICIENCY
ÉCONOMIE DE L'EAU



DESCARGA DUPLA
DESCARGA DOBLE
DUAL FLUSH
DOUBLE DÉBIT



SISTEMA START/STOP
SISTEMA START/STOP
START/STOP SYSTEM
SYSTÈME START/STOP



ENCAIXE COM ROSCA
ENCAJE ROSCADO
TWIST FITTING
MONTAGE TORSION



ENCAIXE RÁPIDO
INSTALACIÓN FÁCIL
FAST INSTALLATION
INSTALLATION SIMPLE



ANTI CONDENSACÃO
ANTICONDENSACIÓN
ANTI CONDENSATION
ANTI CONDENSATION



SILENCIOSO
SILENCIOSO
SILENT
SILENCIEUX



FÁCIL INSTALAÇÃO E MANUTENÇÃO
INSTALACIÓN Y MANTENIMIENTO FÁCIL
EASY INSTALLATION & MAINTENANCE
INSTALLATION ET ENTRETIEN FACILES



PROFUNDIDADE
PROFUNDIDAD
DEPTH
PROFONDEUR



CASQUILHO PLÁSTICO
CASQUILLO PLÁSTICO
PLASTIC FITTING
RACCORD EN PLASTIQUE



CASQUILHO LATÃO
CASQUILLO LATÓN
BRASS FITTING
RACCORD EN LAITON



ANTI-TORÇÃO
ANTI-GIRO
ANTI-TWIST
ANTI-TORSION



CONFORME CE
NORMATIVA CE
CE NORM
NORME CE



UNIVERSAL
UNIVERSAL
UNIVERSAL
UNIVERSEL



SOFT-CLOSE



CAIXA
CAJA
BOX
BOÎTE



TAMANHOS PERSONALIZADOS
TAMANOS PERSONALIZADOS
CUSTOM SIZES
DIMENSIONS PERSONNALISÉES

Autoclismos interiores

Cisternas empotradas

Concealed cisterns

Réservoirs à encastrer

A gama de autoclismos Ctesi destaca-se pela qualidade dos materiais e durabilidade. Equipamos os nossos produtos com torneiras de boia silenciosas de rápido enchimento e válvulas de descarga desenvolvidas para lhe proporcionar a máxima eficiência hídrica.

Contribuímos para que pequenos gestos façam toda a diferença, poupando no consumo de água sem afetar a eficiência e o conforto no uso deste recurso essencial à vida.

La gama de cisternas Ctesi se destaca por la calidad de los materiales utilizados, que tienen una gran resistencia y durabilidad. Equipamos nuestros productos con flotadores silenciosos, para un llenado rápido, y válvulas de descarga diseñadas para proporcionarte la máxima eficiencia del agua. Ayudamos a que los pequeños gestos marquen la diferencia, lo que se traduce en un ahorro en el consumo de agua, sin afectar la eficiencia y la comodidad en el uso de este recurso esencial para la vida en el planeta.

The range of Ctesi cisterns stands out for the material quality, which have a high resistance and durability. We gear our products with silent float valves for fast filling and flushing valves designed to provide you with maximum water efficiency. We help small gestures make the difference by saving water without affecting the efficiency and comfort while using this essential life resource on the planet.

La gamme de réservoirs Ctesi se distingue par la qualité des matériaux utilisés, qui présentent une grande résistance et durabilité. Nous équipons nos produits avec des flotteurs silencieux, pour un remplissage rapide, et avec des mécanismes de chasse conçus pour vous offrir une économie maximale de l'eau. Nous vous aidons pour que de petits gestes font toute la différence à l'heure d'économiser de l'eau, sans affecter l'efficacité et le confort dans l'utilisation de cette ressource essentielle à la vie sur la planète.



Simple

É a solução para instalação em paredes resistentes, ou paredes de gesso, de sanitas ao chão. Equipados com sistema de descarga dupla e torneiras silenciosas, permitem um enchimento rápido e garantem uma rápida instalação, assim como um fácil acesso ao interior através da placa de controle.

Es la opción ideal para instalar inodoros de suelo en paredes resistentes. Están equipadas con un sistema de descarga doble y grifos flotadores silenciosos para un llenado rápido, lo que garantiza una rápida instalación y fácil acceso al interior.

It is the perfect choice for floor-standing toilets in resistant walls. All of them are equipped with a double flush system and silent float taps for quick filling, while assuring a quick installation and easy access to its interior.

C'est le choix idéal pour installer des toilettes de fixation au sol dans des murs robustes. Elles sont équipées d'un mécanisme à double chasse et des robinets flotteurs silencieux pour un remplissage rapide, assurant une installation rapide et un accès facile à l'intérieur.

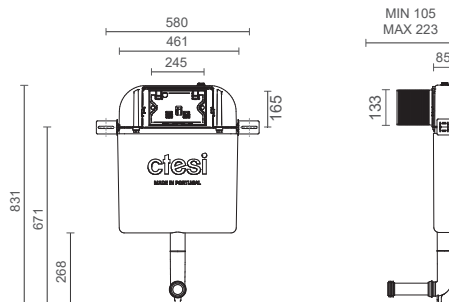
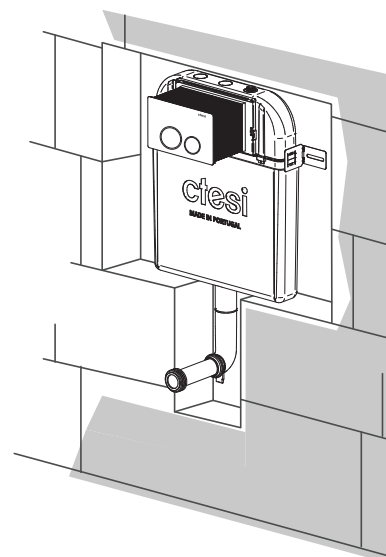

CARACTERÍSTICAS

- Sem estrutura
- Dupla descarga 3/6l; regulável 3/4,5l
- Isolamento anticondensação e acústico em EPS com alvéolos
- Torneira de boia silenciosa
- Profundidade 80 mm
- Reservatório em polipropileno (PP) altamente resistente (Temp. água max. 25°C)
- Instalação em paredes de alvenaria
- Marcação CE: EN 14055
- Eficiência energética: classe A
- Compatível com todas as sanitas de fixação ao chão

FEATURES

- Without frame
- Dual flush 3/6l; adjustable 3/4,5l
- Anti-condensation and cells polystyrene acoustic isolation
- Silent float valve
- Depth 8 cm
- High resistance polypropylene (PP) tank (max. water temperature 25°C)
- Installation on masonry walls
- CE Certification: EN 14055
- Energy Performance Certificate: A
- Compatible with all floor-standing toilets

CARACTERÍSTICAS

- Sin estructura
- Descarga doble 3/6l; ajustable 3/4,5l
- Aislamiento anticondensación y aislamiento acústico en poliestireno con alvéolos
- Grifo flotador silencioso
- Profundidad: 8cm
- Depósito de polipropileno (PP) de alta resistencia (temperatura máxima del agua 25°C)
- Instalación en paredes de albañilería
- Certificación CE: EN 14055
- Certificación Energética: Clase A
- Compatible con todos los inodoros de suelo

CARACTÉRISTIQUE

- Sans structure
- Double chasse 3/6l; ajustable 3/4,5l
- Isolation anti-condensation et isolation acoustique en polystyrène à cellules
- Robinet flotteur silencieux
- Profondeur 8 cm
- Réservoir en polypropylène (PP) haute résistance (température maximale de l'eau 25°C)
- Installation en murs de maçonnerie
- Certification CE: EN 14055
- Certificat de Performance Énergétique: Classe A
- Compatible avec toutes les toilettes au sol





Simple

Dupla descarga
Descarga doble
Dual flush
Double chasse



Reservatório em polipropileno (PP) altamente resistente (Temp. água max. 25°C)
Depósito de polipropileno (PP) de alta resistencia (temperatura máxima del agua 25°C)
High resistance polypropylene (PP) tank (max. water temperature 25°C)
Réservoir en polypropylène (PP) haute résistance (température maximale de l'eau 25°C)

Torneira de boia silenciosa
Grifo flotador silencioso
Silent Inlet Valve
Robinet flotteur silencieux

Isolamento anticondensação e acústico em EPS com alvéolos
Aislamiento anticondensación y aislamiento acústico en poliestireno con alvéolos
Anti-condensation and cells polystyrene acoustic isolation
Isolation anti-condensation et isolation acoustique en polystyrène à cellules

Rede para aplicação em paredes de alvenaria
Malla para instalación en muros de albañilería
Mesh to install toilets in brickwalls
Treillis pour l'installation de toilettes dans les murs de maçonnerie

Tubo de ligação à sanita
Tubo de conexión al inodoro
Toilet connecting pipe
Tuyau de connection au toilette

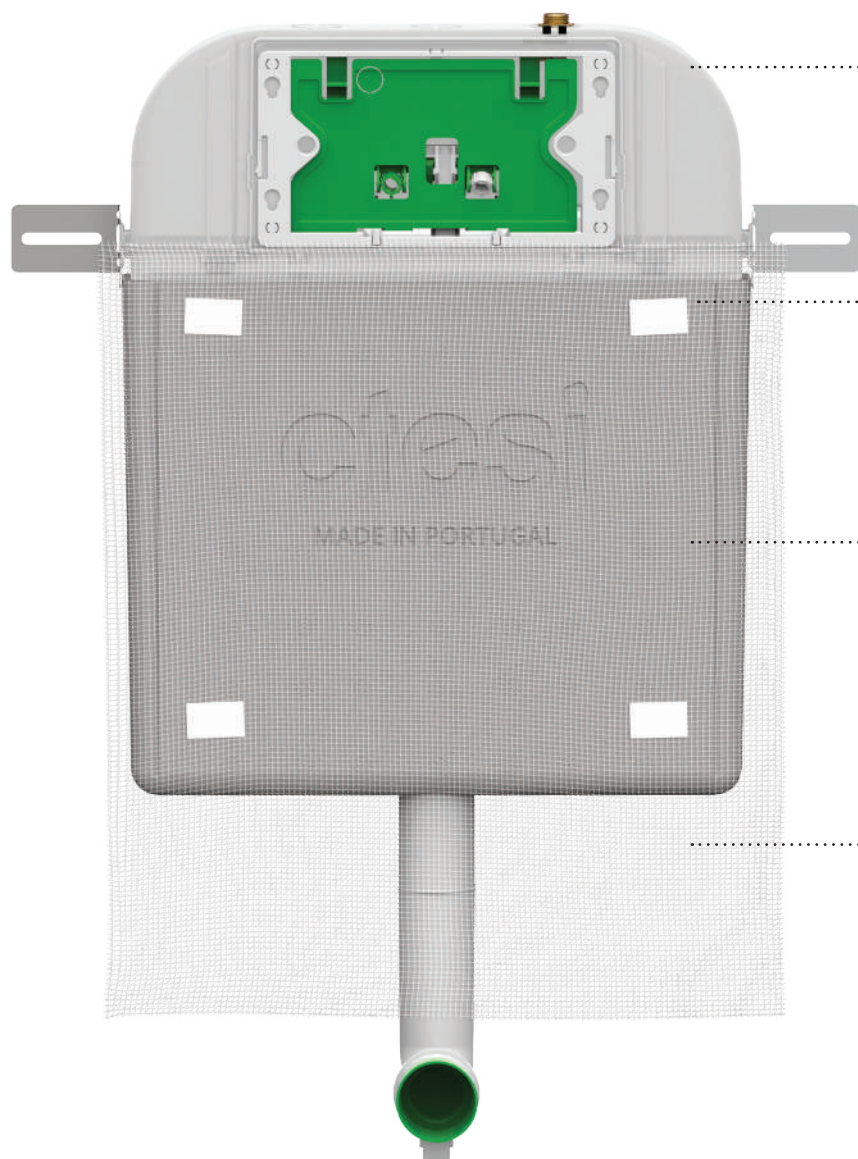

REF.

BK0200200

sem estrutura
sin estructura
without frame
sans structure



€

1

32

88,00

Easy

Autoclismo interior para sanitas suspensas, ideal para a instalação de louças sanitárias em paredes resistentes. Os autoclismos EASY são projetados para aplicação em paredes de alvenaria.

Easy es la opción perfecta para instalar artículos sanitarios en paredes robustas como la albañilería. Las estructuras Easy están diseñadas para una fácil aplicación incrustada en la albañilería.

Easy is the perfect option to install sanitary items in resistant walls, such as brickwalls. Our Easy frames are designed for in-wall application on masonry walls.

Easy est l'option idéale pour l'installation d'appareils sanitaires aux murs résistants. Les systèmes Easy sont conçus pour une application facile et encastré dans la maçonnerie.

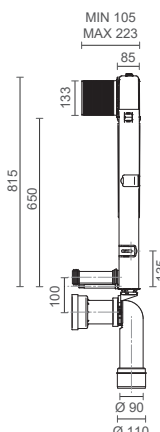
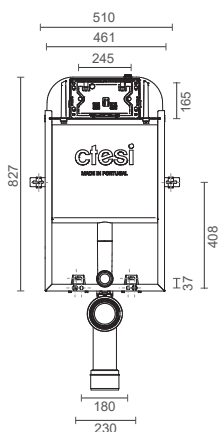
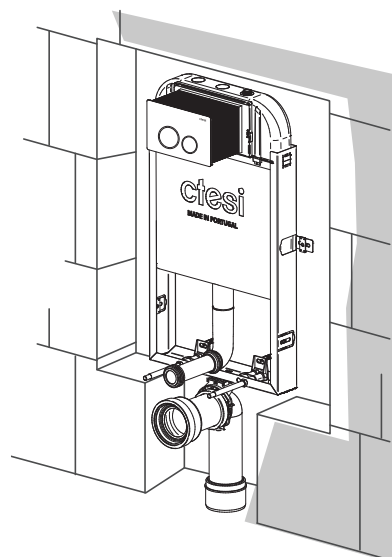

CARACTERÍSTICAS

- Com estrutura para paredes de alvenaria
- Dupla descarga 3/6; regulável 3/4,5l
- Isolamento anticondensação e acústico em EPS com alvéolos
- Torneira de boia silenciosa
- Profundidade 80 mm
- Reservatório em polipropileno (PP) altamente resistente (Temp. água max. 25°C)
- Marcação CE: EN14055
- Eficiência energética: classe A
- Curva de esgoto ajustável em profundidade

FEATURES

- With frame for masonry walls
- Dual flush 3/6l; adjustable 3/4,5l
- Anti-condensation and cells polystyrene acoustic isolation
- Silent float valve
- Depth 8 cm
- High resistance polypropylene (PP) tank (max. water temperature 25°C)
- CE Certification: EN 14055
- Energy Performance Certificate: A
- Depth adjustable sanitary sewer curve

CARACTERÍSTICAS

- Con estructura para paredes de albañilería
- Descarga doble 3/6l; ajustable 3/4,5l
- Aislamiento anticondensación y aislamiento acústico en poliestireno con alvéolos
- Grifo flotador silencioso
- Profundidad: 8cm
- Depósito de polipropileno (PP) de alta resistencia (temperatura máxima del agua 25°C)
- Certificación CE: EN 14055
- Certificación Energética: Clase A
- Curva de alcantarillado sanitario ajustable en profundidad

CARACTÉRISTIQUE

- Avec structure pour murs en maçonnerie
- Double chasse 3/6l; ajustable 3/4,5l
- Isolation anti-condensation et isolation acoustique en polystyrène à cellules
- Robinet flotteur silencieux
- Profondeur 8 cm
- Réservoir en polypropylène (PP) haute résistance (température maximale de l'eau 25°C)
- Certification CE: EN 14055
- Certificat de Performance Énergétique: Classe A
- Courbe d'égout sanitaire réglable en profondeur





Easy

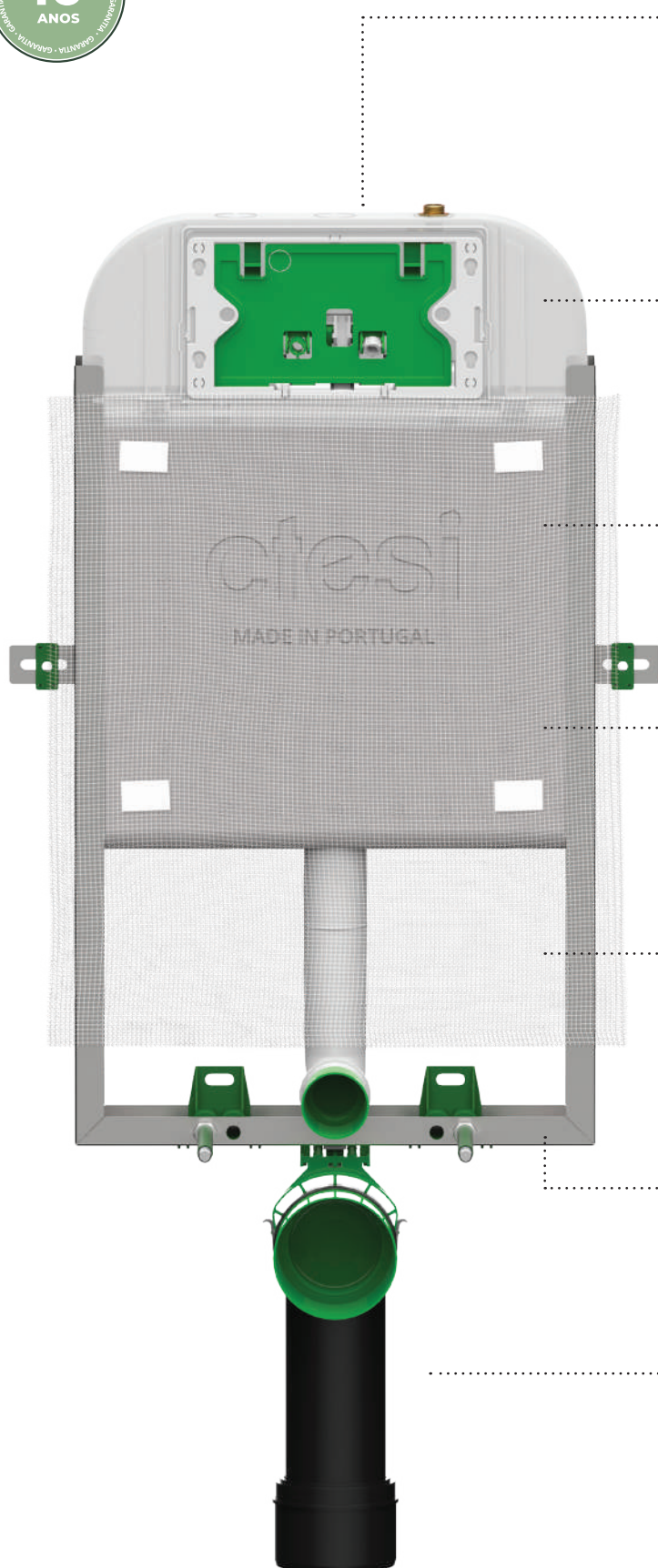

Dupla descarga
Descarga doble
Dual flush
Double chasse

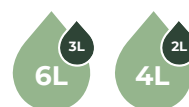

Reservatório em polipropileno (PP) altamente resistente (Temp. água max. 25°C)
Depósito de polipropileno (PP) de alta resistencia (temperatura máxima del agua 25°C)
High resistance polypropylene (PP) tank (max. water temperature 25°C)
Réservoir en polypropylène (PP) haute résistance (température maximale de l'eau 25°C)

Torneira de boia silenciosa
Grifo flotador silencioso
Silent Inlet Valve
Robinet flotteur silencieux

Isolamento anticondensação e acústico em EPS com alvéolos
Aislamiento anticondensación y aislamiento acústico en poliestireno con alvéolos
Anti-condensation and cells polystyrene acoustic isolation
Isolation anti-condensation et isolation acoustique en polystyrène à cellules

Rede para aplicação em paredes de alvenaria
Malla para instalación en muros de albañilería
Mesh to install toilets in brickwalls
Treillis pour l'installation de toilettes dans les murs de maçonnerie

Com estrutura para paredes de alvenaria
Con estructura para paredes de albañilería
With frame for masonry walls
Avec structure pour murs en maçonnerie

Curva de esgoto ajustável em profundidade
Curva de alcantarillado sanitario ajustable en profundidad
Depth adjustable sanitary sewer curve
Courbe d'égout sanitaire réglable en profondeur

REF.

BK0200220

com estrutura
con estructura
with frame
avec structure



€

1

30

120,00

Easy com pés

con patas · with feet · avec pieds

Autoclismo interior ideal para a instalação de louças sanitárias em paredes resistentes. Os autoclismos EASY são projetados para aplicação em paredes de alvenaria. Os pés em aço galvanizado permitem auxiliar a montagem da estrutura EASY para aplicação de louça suspensa. Os pés Easy permitem ajustar a altura de fixação da estrutura Easy com autoclismo interior. Estruturas galvanizadas para encastrar em paredes de alvenaria, para instalação de louças sanitárias suspensas. Posição da curva de esgoto regulável em profundidade.

Cisterna empotrada perfecta para instalar artículos sanitarios en paredes resistentes. Las cisternas EASY están diseñadas para que sean aplicadas en paredes de albañería. Los pies de acero galvanizado ayudan a montar la estructura EASY para la aplicación de sanitarios suspendidos. Las patas ajustan fácilmente la altura de una cisterna empotrada con estructura Easy. Estructuras galvanizadas para empotrar en paredes resistentes, para instalación de sanitarios suspendidos. La posición de la curva de alcantarillado es ajustable en profundidad.

Concealed flush cisterns are perfect for installing sanitary items on resistant walls. Our EASY cisterns are designed to be applied on brickwalls. Galvanized steel feet help install the EASY structure for suspended toilet applications. The feet easily adjust the height of a concealed cistern with an Easy frame. Galvanized structure to apply on resistant walls for suspended toilets. The sewer's curve position is adjustable in depth.

Les réservoirs à encastrer sont parfaits pour l'installation d'appareils sanitaires aux murs résistants. Les réservoirs EASY sont conçus pour une facile application et encastrer dans la maçonnerie. Les pieds en acier galvanisé aident à installer la structure EASY pour les applications de toilettes suspendues. Les pieds permettent régler facilement la hauteur d'un réservoir à encastrer avec la structure Easy. Structure galvanisée à encastrer sur des murs résistants pour l'installation toilettes suspendues. La position de la courbe de l'égout sanitaire est réglable en profondeur.

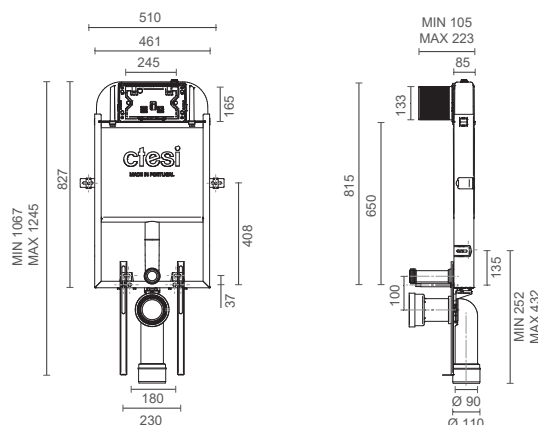
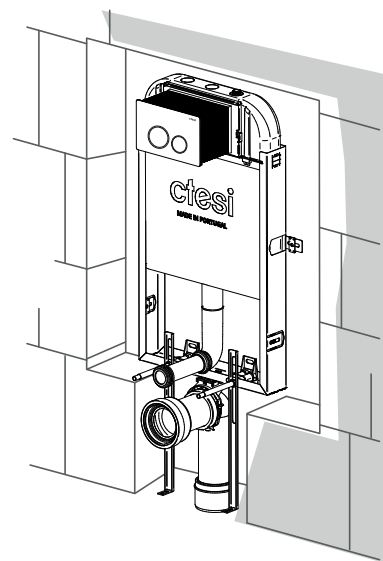

CARACTERÍSTICAS

- Com estrutura para paredes de alvenaria
- Com pés ajustáveis
- Dupla descarga 3/6l; regulável 3/4,5l
- Isolamento anticondensação e acústico em EPS com alvéolos
- Torneira de boia silenciosa
- Profundidade 80 mm
- Reservatório em polipropileno (PP) altamente resistente (Temp. água máx. 25°C)
- Marcação CE: EN 14055
- Eficiência energética: classe A
- Curva de esgoto ajustável em profundidade

FEATURES

- With frame for masonry walls
- With adjustable feet
- Dual flush 3/6l; adjustable 3/4,5l
- Anti-condensation and cells polystyrene acoustic isolation
- Silent float valve
- Depth 8 cm
- High resistance polypropylene (PP) tank (max. water temperature 25°C)
- CE Certification: EN 14055
- Energy Performance Certificate: A
- Depth adjustable sanitary sewer curve

CARACTERÍSTICAS

- Con estructura para paredes de albañería
- Con pies ajustables
- Descarga doble 3/6l; ajustable 3/4,5l
- Aislamiento anticondensación y aislamiento acústico en poliestireno con alvéolos
- Grifo flotador silencioso
- Profundidad: 8cm
- Depósito de polipropileno (PP) de alta resistencia (temperatura máxima del agua 25°C)
- Certificación CE: EN 14055
- Certificación Energética: Clase A
- Curva de alcantarillado sanitario ajustable en profundidad

CARACTÉRISTIQUE

- Avec structure pour murs en maçonnerie
- Avec des pieds réglables
- Double chasse 3/6l; ajustable 3/4,5l
- Isolation anti-condensation et isolation acoustique en polystyrène à cellules
- Robinet flotteur silencieux
- Profondeur 8 cm
- Réservoir en polypropylène (PP) haute résistance (température maximale de l'eau 25°C)
- Certification CE: EN 14055
- Certificat de Performance Énergétique: Classe A
- Courbe d'égout sanitaire réglable en profondeur





Easy com pés

con patas · with feet · avec pieds

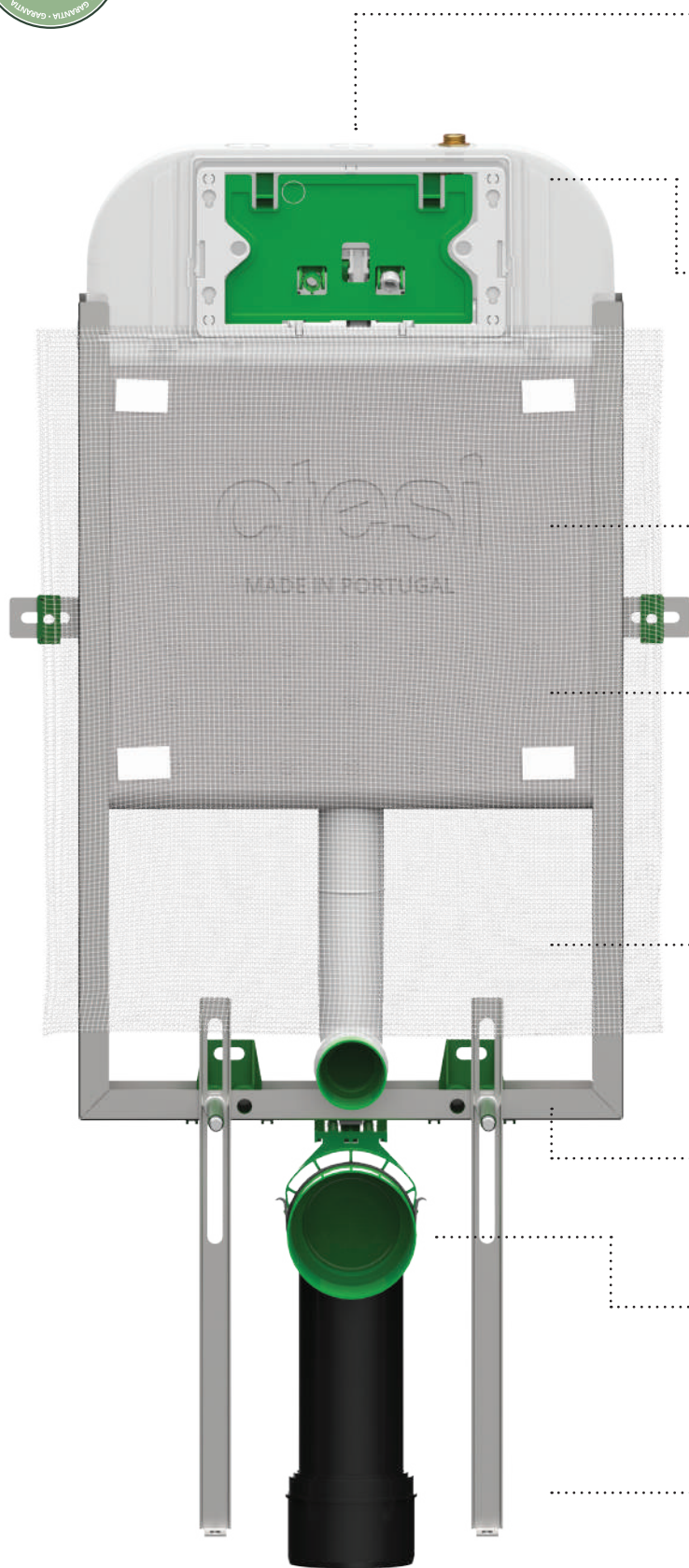

Dupla descarga

Descarga doble
Dual flush
Double chasse

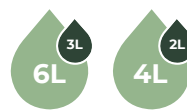

Reservatório em polipropileno (PP) altamente resistente (Temp. água max. 25°C)

Depósito de polipropileno (PP) de alta resistencia (temperatura máxima del agua 25°C)

High resistance polypropylene (PP) tank (max. water temperature 25°C)

Réservoir en polypropylène (PP) haute résistance (température maximale de l'eau 25°C)

Torneira de boia silenciosa

Grifo flotador silencioso
Silent Inlet Valve
Robinet flotteur silencieux

Isolamento anticondensação e acústico em EPS com alvéolos

Aislamiento anticondensación y aislamiento acústico en poliestireno con alvéolos

Anti-condensation and cells polystyrene acoustic isolation

Isolation anti-condensation et isolation acoustique en polystyrène à cellules

Rede para aplicação em paredes de alvenaria

Malla para instalación en muros de albañilería
Mesh to install toilets in brickwalls

Treillis pour l'installation de toilettes dans les murs de maçonnerie

Com estrutura para paredes de alvenaria

Con estructura para paredes de albañilería
With frame for masonry walls
Avec structure pour murs en maçonnerie

Curva de esgoto ajustável em profundidade

Curva de alcantarillado sanitario ajustable en profundidad

Depth adjustable sanitary sewer curve

Courbe d'égout sanitaire réglable en profondeur

Com pés ajustáveis

Con pies ajustables
With adjustable feet
Avec des pieds réglables

REF.

BK0200221

com estrutura e pés
con estructura y patas
with frame and feet
avec structure et pieds



€

1

30

140,00

Solid

Solid é um sistema de instalação com alta resistência mecânica para a instalação de louças sanitárias em paredes de gesso. Estrutura metálica de fixação à parede e ao chão, regulável em altura para instalação de louças sanitárias suspensas. Aplicação em paredes de alvenaria, paredes ligeiras ou calha técnica. Posição da curva de esgoto regulável em profundidade.

Solid es un sistema de instalación de alta resistencia mecánica para la instalación de cerámica sanitaria en paredes ligeras. Estructura metálica de fijación a la pared y al suelo, regulable en altura para la instalación de inodoros suspendidos. Para aplicar en paredes resistentes, ligeras o canaletas técnicas. La posición de la curva de alcantarillado es ajustable en profundidad.

Solid is a system with high mechanical resistance to install sanitary items in plasterboard walls. Height adjustable metal structure for wall and floor fixing for suspended toilets. To be applied on resistant/ plasterboard walls or technical gutters. The sewer's curve position is adjustable in depth.

Solid est un système d'installation à haute résistance mécanique pour l'installation d'appareils sanitaires dans les murs de placoplâtre. Structure métallique à fixer aux murs et aux sols, réglable en hauteur, pour l'installation de toilettes suspendues. Pour application sur des murs résistants et de placoplâtre ou gouttières techniques. La position de la courbe de l'égout sanitaire est réglable en profondeur.

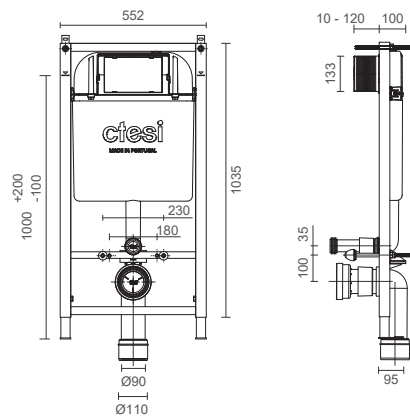
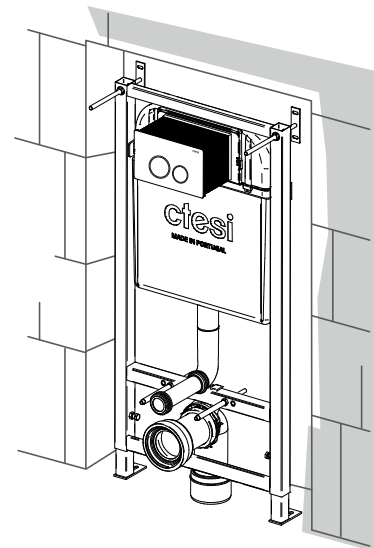

CARACTERÍSTICAS

- Com estrutura para paredes de alvenaria, paredes ligeiras ou calha técnica
- Dupla descarga 3/6l; regulável 3/4,5l
- Isolamento anticondensação e acústico em EPS com alvéolos
- Torneira de boia silenciosa
- Profundidade 80 mm
- Suporta até 400 Kg
- Reservatório em polipropileno (PP) altamente resistente (Temp. água máx. 25°C)
- Marcação CE: EN 14055
- Eficiência energética: classe A
- Curva de esgoto ajustável em profundidade
- Altura regulável de 0-200 mm

FEATURES

- With frame for masonry walls, plasterboard walls or technical gutters
- With adjustable feet
- Dual flush 3/6l; adjustable 3/4,5l
- Anti-condensation and cells polystyrene acoustic isolation
- Silent float valve
- Depth 8 cm
- Holds up to 400KG
- High resistance polypropylene (PP) tank (max. water temperature 25°C)
- CE Certification: EN 14055
- Energy Performance Certificate: A
- Depth adjustable sanitary sewer curve
- Adjustable height from 0 to 300mm

CARACTERÍSTICAS

- Con estructura para paredes de albañilería, paredes ligeras o canaletas técnicas
- Con pies ajustables
- Descarga doble 3/6l; ajustable 3/4,5l
- Aislamiento anticondensación y aislamiento acústico en poliestireno con alvéolos
- Grifo flotador silencioso
- Profundidad: 8Cm
- Soporta hasta 400KG
- Depósito de polipropileno (PP) de alta resistencia temperatura máxima del agua 25°C)
- Certificación CE: EN 14055
- Certificación Energética: Clase A
- Curva de alcantarillado sanitario ajustable en profundidad
- Altura ajustable de 0 a 300mm

CARACTÉRISTIQUE

- Avec structure pour murs en maçonnerie, murs de placoplâtre ou gouttières techniques
- Avec des pieds réglables
- Double chasse 3/6l; ajustable 3/4,5l
- Isolation anti-condensation et isolation acoustique en polystyrène à cellules
- Robinet flotteur silencieux
- Profondeur 8 cm
- Peut contenir jusqu'à 400KG
- Réservoir en polypropylène (PP) haute résistance (température maximale de l'eau 25°C)
- Certification CE: EN 14055
- Certificat de Performance Énergétique: Classe A
- Courbe d'égout sanitaire réglable en profondeur
- Hauteur réglable de 0 à 300mm





Solid

Suporta até 400 Kg
 Soporta hasta 400kg
 Holds up to 400kg
 Peut contenir jusqu'à 400kg



Dupla descarga
 Descarga doble
 Dual flush
 Double chasse

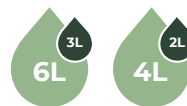

Reservatório em polipropileno (PP) altamente resistente (Temp. água max. 25°C)
 Depósito de polipropileno (PP) de alta resistencia (temperatura máxima del agua 25°C)
 High resistance polypropylene (PP) tank (max. water temperature 25°C)
 Réservoir en polypropylène (PP) haute résistance (température maximale de l'eau 25°C)

Torneira de boia silenciosa
 Grifo flotador silencioso
 Silent Inlet Valve
 Robinet flotteur silencieux

Isolamento anticondensação e acústico em EPS com alvéolos

Aislamiento anticondensación y aislamiento acústico en poliestireno con alvéolos
 Anti-condensation and cells polystyrene acoustic isolation
 Isolation anti-condensation et isolation acoustique en polystyrène à cellules

Com estrutura para paredes de alvenaria, paredes ligeiras ou calha técnica

Con estructura para paredes de albañilería, paredes ligeras o canaletas técnicas
 With frame for masonry walls, plasterboard walls or technical gutters
 Avec structure pour murs en maçonnerie, murs de placoplatre ou gouttières techniques

Curva de esgoto ajustável em profundidade

Curva de alcantarillado sanitario ajustable en profundidad
 Depth adjustable sanitary sewer curve
 Courbe d'égout sanitaire réglable en profondeur

Altura regulável de 0-300 mm

Altura ajustable de 0 a 300mm
 Adjustable height from 0 to 300mm
 Hauteur réglable de 0 à 300mm



REF.

BK0200240

com estrutura
 con estructura
 with frame
 avec structure



€

1

15

190,00

Self simples

O SELF SIMPLES é o sistema ideal para a instalação de louça sanitária suspensa em paredes ligeiras. O isolamento anti condensação evita a acumulação de águas e o isolamento acústico garante-lhe um sistema silencioso. É um sistema adaptável que lhe permite regular, a altura entre os 0-300mm, o sistema de dupla descarga ou mesmo a posição da curva de esgoto.

El modelo SELF SIMPLES es el sistema perfecto para la instalación de inodoros suspendidos en paredes ligeras. El aislamiento anticondensación evita la acumulación de agua y el aislamiento acústico garantiza un sistema silencioso. Es un sistema adaptable que permite ajustar la altura entre los 0-300mm, el sistema de descarga doble o incluso la posición de la curva de alcantarillado.

SELF SIMPLES is the perfect system for suspended toilets in plasterboard walls. The anti-condensation insulation prevents water accumulation and the acoustic insulation ensures a quiet system. It has an adaptable system that allows you to adjust the height between 0-300mm, the double flush system or even the sewer curve's position.

Le modèle SELF SIMPLES c'est le système parfait pour l'installation de toilettes suspendues sur des murs de placoplatre. L'isolation anti-condensation empêche l'accumulation d'eau et l'isolation acoustique assure un système silencieux. C'est un système adaptable qui vous permet d'ajuster la hauteur entre 0-300mm, le système à double chasse ou encore la position de la courbe d'égout sanitaire.

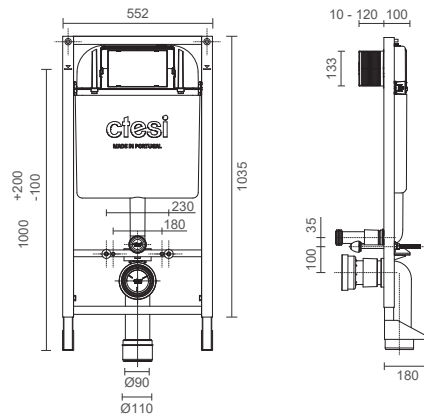
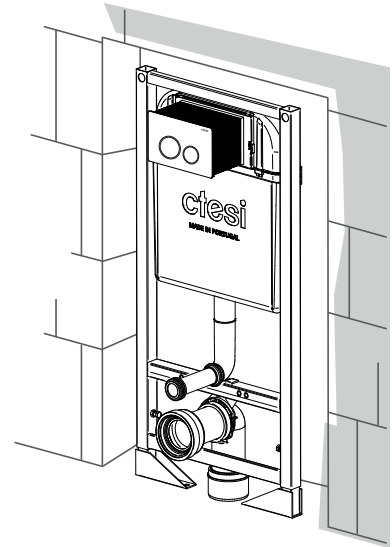

CARACTERÍSTICAS

- Com estrutura para fixação ao chão em paredes ligeiras
- Dupla descarga 3/6l; regulável 3/4,5l
- Isolamento anticondensação e acústico em EPS com alvéolos
- Torneira de boia silenciosa
- Profundidade 80 mm
- Suporta até 400kg
- Reservatório em polipropileno (PP) altamente resistente (Temp. água máx. 25°C)
- Marcação CE: EN 14055
- Eficiência energética: classe A
- Curva de esgoto ajustável em profundidade
- Altura regulável de 0-300 mm

FEATURES

- With floor fixing structure for plasterboard walls
- Dual flush 3/6l; adjustable 3/4,5l
- Anti-condensation and cells polystyrene acoustic isolation
- Silent float valve
- Depth 8 cm
- Holds up to 400KG
- High resistance polypropylene (PP) tank (max. water temperature 25°C)
- CE Certification: EN 14055
- Energy Performance Certificate: A
- Depth adjustable sanitary sewer curve
- Adjustable height from 0 to 300mm

CARACTERÍSTICAS

- Con estructura para fijación al suelo en paredes ligeras
- Descarga doble 3/6l; ajustable 3/4,5l
- Aislamiento anticondensación y aislamiento acústico en poliestireno con alvéolos
- Grifo flotador silencioso
- Profundidad: 8Cm
- Soporta hasta 400KG
- Depósito de polipropileno (PP) de alta resistencia (temperatura máxima del agua 25°C)
- Certificación CE: EN 14055
- Certificación Energética: Clase A
- Curva de alcantarillado sanitario ajustable en profundidad
- Altura ajustable de 0 a 300mm

CARACTÉRISTIQUE

- Avec structure de fixation au sol pour murs de placoplatre
- Double chasse 3/6l; ajustable 3/4,5l
- Isolation anti-condensation et isolation acoustique en polystyrène à cellules
- Robinet flotteur silencieux
- Profondeur 8 cm
- Peut contenir jusqu'à 400KG
- Réservoir en polypropylène (PP) haute résistance (température maximale de l'eau 25°C)
- Certification CE: EN 14055
- Certificat de Performance Énergétique: Classe A
- Courbe d'égout sanitaire réglable en profondeur
- Hauteur réglable de 0 à 300mm





Self simples



Suporta até 400 Kg
 Soporta hasta 400kg
 Holds up to 400kg
 Peut contenir jusqu'à 400kg



Dupla descarga
 Descarga doble
 Dual flush
 Double chasse



Reservatório em polipropileno (PP) altamente resistente (Temp. água max. 25°C)

Depósito de polipropileno (PP) de alta resistencia (temperatura máxima del agua 25°C)

High resistance polypropylene (PP) tank (max. water temperature 25°C)

Réservoir en polypropylène (PP) haute résistance (température maximale de l'eau 25°C)

Torneira de boia silenciosa

Grifo flotador silencioso
 Silent Inlet Valve
 Robinet flotteur silencieux

Isolamento anticondensação e acústico em EPS com alvéolos

Aislamiento anticondensación y aislamiento acústico en poliestireno con alvéolos

Anti-condensation and cells polystyrene acoustic isolation

Isolation anti-condensation et isolation acoustique en polystyrène à cellules

Com estrutura para paredes de alvenaria, paredes ligeiras ou calha técnica

Con estructura para paredes de albañilería, paredes ligeras o canaletas técnicas

With frame for masonry walls, plasterboard walls or technical gutters

Avec structure pour murs en maçonnerie, murs de placoplatre ou gouttières techniques

Curva de esgoto ajustável em profundidade

Curva de alcantarillado sanitario ajustable en profundidad

Depth adjustable sanitary sewer curve

Courbe d'égout sanitaire réglable en profondeur

Altura regulável de 0-300 mm

Altura ajustable de 0 a 300mm

Adjustable height from 0 to 300mm

Hauteur réglable de 0 à 300mm

REF.

BK0200260

com estrutura
 con estructura
 with frame
 avec structure



€

1

15

296,00

Self duplo

SELF DUPLO é a escolha acertada na instalação de louças sanitárias suspensas “costas com costas” na mesma parede. O isolamento anti condensação evita a acumulação de águas, e o isolamento acústico, e garante-lhe um real sistema silencioso. Permite-lhe regular a altura entre os 0-300mm, o sistema de dupla descarga ou mesmo a posição da curva de esgoto.

El SELF DUPLO es la opción correcta al instalar dos inodoros suspendidos tipo “espalda con espalda” en la misma pared. El aislamiento anticondensación evita la acumulación de agua y el aislamiento acústico garantiza un sistema silencioso. Te permite ajustar la altura entre los 0-300mm, el sistema de descarga doble o incluso la posición de la curva de alcantarillado.

The SELF DUPLO model is the right choice when it comes to two “back to back” suspended toilets on the same wall. The anti-condensation insulation prevents water accumulation and the acoustic insulation ensures a quiet system. It allows you to adjust the height between 0-300mm, the double flush system or even the sewer curve's position.

Le modèle SELF DUPLO est parfait lorsqu'il s'agit de deux toilettes suspendues «dos à dos» sur le même mur. L'isolation anti-condensation empêche l'accumulation d'eau et l'isolation acoustique assure un système silencieux. Le système vous permet d'ajuster la hauteur entre 0-300mm, le système à double chasse ou encore la position de la courbe d'égout sanitaire.

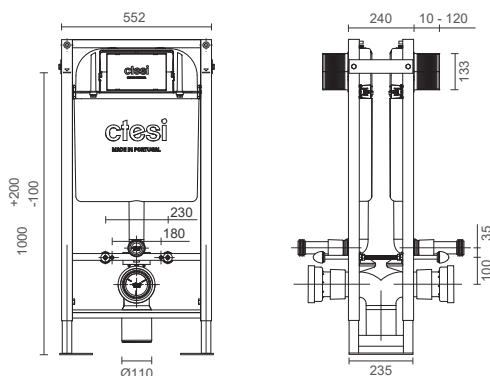
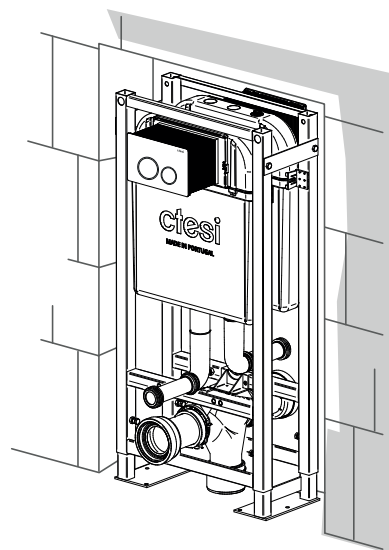

CARACTERÍSTICAS

- Com estrutura para fixação ao chão em paredes ligeiras
- Estrutura metálica para aplicação de 2 sanitas suspensas “costas com costas”
- Dupla descarga 3/6l; regulável 3/4,5l
- Isolamento anticondensação e acústico em esferovite com alvéolos
- Torneira de boia silenciosa
- Profundidade 80 mm
- Suporta 400 kg
- Reservatório em polipropileno (PP) altamente resistente (Temp. água máx. 25°C)
- Marcação CE: EN 14055
- Eficiência energética: classe A
- Curva de esgoto ajustável em profundidade
- Altura regulável de 0-300 mm

FEATURES

- With floor fixing structure for plasterboard walls
- Metallic structure for 2 “back to back” type suspended toilets
- Dual flush 3/6l; adjustable 3/4,5l
- Anti-condensation and cells polystyrene acoustic isolation
- Silent float valve
- Depth 8 cm
- Holds up to 400KG
- High resistance polypropylene (PP) tank (max. water temperature 25°C)
- CE Certification: EN 14055
- Energy Performance Certificate: A
- Depth adjustable sanitary sewer curve
- Adjustable height from 0 to 300mm

CARACTERÍSTICAS

- Con estructura para fijación al suelo en paredes ligeras
- Estructura metálica para aplicar 2 inodoros suspendidos tipo “espalda con espalda”
- Descarga doble 3/6l; ajustable 3/4,5l
- Aislamiento anticondensación y aislamiento acústico en poliestireno con alvéolos
- Grifo flotador silencioso
- Profundidad: 8Cm
- Soporta hasta 400KG
- Depósito de polipropileno (PP) de alta resistencia (temperatura máxima del agua 25°C)
- Certificación CE: EN 14055
- Certificación Energética: Clase A
- Curva de alcantarillado sanitario ajustable en profundidad
- Altura ajustable de 0 a 300mm

CARACTÉRISTIQUE

- Avec structure de fixation au sol pour murs de placo-plâtre
- Structure métallique pour 2 toilettes suspendues de type «dos à dos»
- Double chasse 3/6l; ajustable 3/4,5l
- Isolation anti-condensation et isolation acoustique en polystyrène à cellules
- Robinet flotteur silencieux
- Profondeur 8 cm
- Peut contenir jusqu'à 400KG
- Réservoir en polypropylène (PP) haute résistance (température maximale de l'eau 25°C)
- Certification CE: EN 14055
- Certificat de Performance Énergétique: Classe A
- Courbe d'égout sanitaire réglable en profondeur
- Hauteur réglable de 0 à 300mm





Self duplo



Suporta até 400 Kg
Soporta hasta 400kg
Holds up to 400kg
Peut contenir jusqu'à 400kg

Dupla descarga
Descarga doble
Dual flush
Double chasse



Reservatório em polipropileno (PP) altamente resistente (Temp. água max. 25°C)

Depósito de polipropileno (PP) de alta resistencia (temperatura máxima del agua 25°C)

High resistance polypropylene (PP) tank (max. water temperature 25°C)

Réservoir en polypropylène (PP) haute résistance (température maximale de l'eau 25°C)

Torneira de boia silenciosa

Grifo flotador silencioso
Silent Inlet Valve
Robinet flotteur silencieux

Isolamento anticondensação e acústico em EPS com alvéolos

Aislamiento anticondensación y aislamiento acústico en poliestireno con alvéolos

Anti-condensation and cells polystyrene acoustic isolation

Isolation anti-condensation et isolation acoustique en polystyrène à cellules

Estrutura metálica para aplicação de 2 sanitas suspensas "costas com costas"

Estructura metálica para aplicar 2 inodoros suspendidos tipo "espalda con espalda"

Metallic structure for 2 "back to back" type suspended toilets

Structure métallique pour 2 toilettes suspendues de type «dos à dos»

Com estrutura para paredes de alvenaria ou paredes ligeiras

Con estructura para paredes de albañilería, paredes ligeras o canaletas técnicas

With frame for masonry walls, plasterboard walls or technical gutters

Avec structure pour murs en maçonnerie, murs de placoplatre ou gouttières techniques

Curva de esgoto ajustável em profundidade

Curva de alcantarillado sanitario ajustable en profundidad

Depth adjustable sanitary sewer curve

Courbe d'égout sanitaire réglable en profondeur

Altura regulável de 0-300 mm

Altura ajustable de 0 a 300mm

Adjustable height from 0 to 300mm

Hauteur réglable de 0 à 300mm



REF.

BK0200261

com estrutura e pés
con estructura y patas
with frame and feet
avec structure et pieds



€

1

15

534,00

Solid & Orix

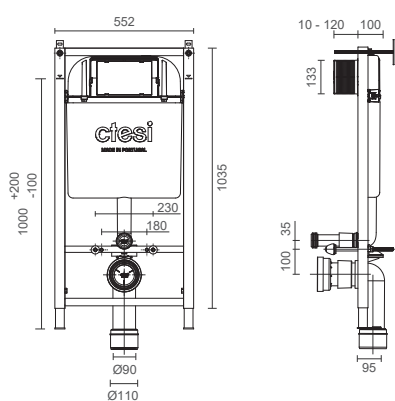

Easy & Orix

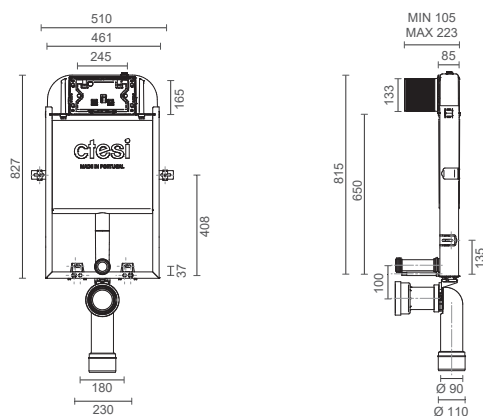

REF.				€
BK0203160	cromado · cromo chrome · chromée	1	15	210,00
BK0203162	preto · negro black · noir	1	15	210,00
BK0203163	branco · blanco white · blanc	1	15	210,00

REF.				€
BK0203170	cromado · cromo chrome · chromée	1	30	155,00
BK0203172	preto · negro black · noir	1	30	155,00
BK0203173	branco · blanco white · blanc	1	30	155,00

Solid & Lyra

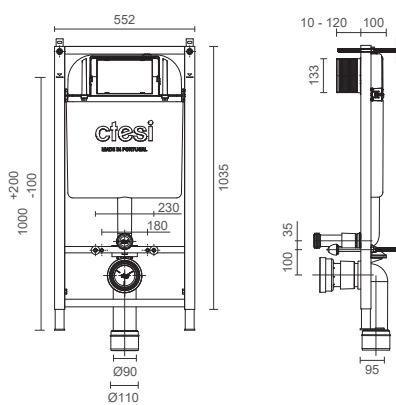

REF.			€
BK0203180	cromado · cromo chrome · chromée	1 15	210,00
BK0203182	preto · negro black · noir	1 15	210,00
BK0203183	branco · blanco white · blanc	1 15	210,00

Easy & Lyra

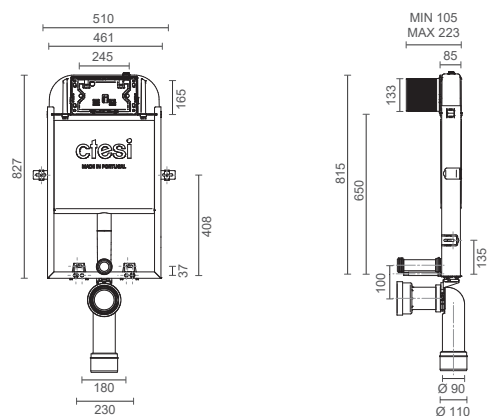
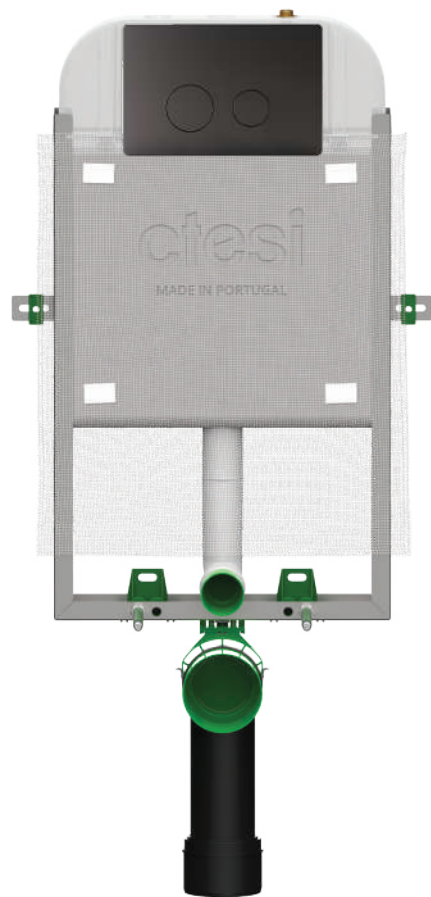

REF.			€
BK0203190	cromado · cromo chrome · chromée	1 30	155,00
BK0203192	preto · negro black · noir	1 30	155,00
BK0203193	branco · blanco white · blanc	1 30	155,00

Estruturas de instalação · Estructuras metálicas Concealed frames · Structures métalliques

Com a gama de soluções para estruturas sanitárias embutidas Ctesi tem toda a liberdade para criar o seu espaço de banho com mais espaço livre, num forte compromisso entre a fiabilidade, a eficiência hídrica e o design. Toda a gama foi desenvolvida para oferecer a melhor prestação em utilizações intensivas, quer seja para espaços públicos ou privados.

Con la gama de opciones para estructuras sanitarias empotradas, con un fuerte compromiso entre la fiabilidad, la eficiencia del agua y el diseño, puedes crear tu baño con más espacio libre. Estos productos han sido creados para tener el mejor desempeño en un uso intensivo, tanto en espacios públicos como en espacios privados.

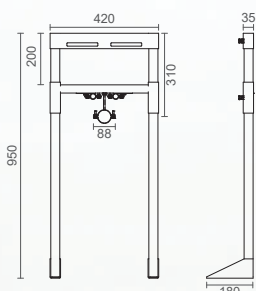

You can create your bathroom with more free space thanks to our range of in-wall reliable, efficient and modern design options. These products are designed to have the best performance in intensive use mode, for either public or private spaces.

Vous pouvez créer votre salle de bain avec plus d'espace libre grâce à notre gamme de produits à encastrer fiables, efficaces et modernes. Ces produits sont conçus pour offrir les meilleures performances en utilisation intensive, soit des espaces publics ou privés.



- Estrutura metálica para lavatório suspenso
- Fixação à parede ou ao chão (em paredes ligeiras)
- Altura ajustável
- Suporta até 150 kg
- Estructura metálica para lavabo suspenso
- Fijación a la pared o al suelo (en paredes de cartón yeso)
- Altura ajustable
- Soporta hasta 150 kg
- Metal structure for suspended washbasin
- Wall or floor fixing (for plasterboard walls)
- Adjustable height
- Holds up to 150 kg
- Structure métallique pour lavabo suspendue
- Fixation au mur ou au sol (dans les murs de plaque de plâtre)
- Hauteur réglable
- Supporte jusqu'à 150 kg

SET

REF.				€
BK0204020	estrutura lavatório · estructura para lavabo structure for washbasin · structure pour lavabo	1	60	199,80



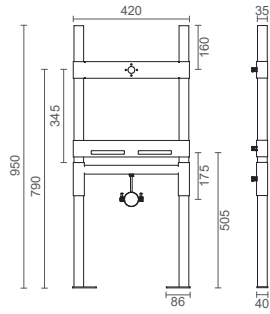

- Estrutura metálica para urinol
- Fixação à parede e ao chão
- Fácil instalação e manutenção
- Altura ajustável
- Suporta até 150 kg

- Estructura metálica para urinario
- Fijación a la pared o al suelo
- Instalación y mantenimiento fáciles
- Altura ajustable
- Soporta hasta 150 kg

- Metal structure for urinol
- Wall or floor fixing
- Easy installation and maintenance
- Adjustable height
- Holds up to 150 kg

- Structure métallique pour urinoir
- Fixation au mur ou au sol
- Installation et maintenance faciles
- Hauteur réglable
- Supporte jusqu'à 150 kg

RIG

REF.				€
BK0204030	estrutura urinol estructura para urinario urinol frame structure pour urinoir	1	60	254,00

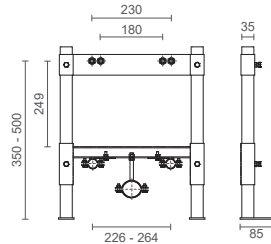
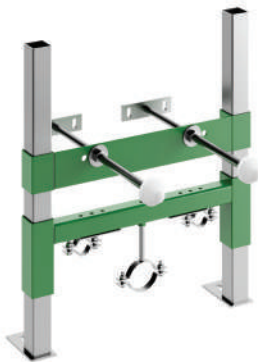

- Estrutura metálica para bidé
- Fixação à parede e ao chão
- Fácil instalação e manutenção
- Altura ajustável
- Suporta até 400 kg

- Estructura metálica para bidet
- Instalación y mantenimiento fácil
- Altura ajustable
- Ancho promedio 420mm
- Suporta hasta 400 kg

- Metallic frame for bidet
- Easy installation and maintenance
- Adjustable height
- Overall width 420mm
- Holds up to 400 kg

- Structure métallique pour bidet
- Installation et entretien faciles
- Réglable en hauteur
- Largeur hors tout 420mm
- Supporte jusqu'à 400 kg

LEAD

REF.				€
BK0204010	estrutura de bidé estructura de bidé bidet frame structure bidet	1	60	120,60

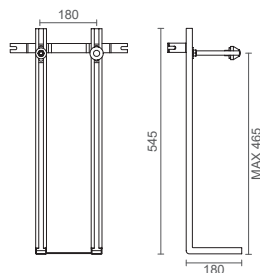

- Estrutura metálica para bidé
- Fácil instalação e manutenção
- Altura ajustável
- Suporta até 400 kg

- Estructura metálica para bidet
- Instalación y mantenimiento fácil
- Altura ajustable
- Suporta hasta 400 kg

- Metallic frame for bidet
- Easy installation and maintenance
- Adjustable height
- Holds up to 400 kg

- Structure métallique pour bidet
- Installation et entretien faciles
- Réglable en hauteur
- Supporte jusqu'à 400 kg

LIGHT

REF.				€
BK0204100	estrutura de bidé estructura de bidé bidet frame structure bidet	1	100	49,30

Soft Touch

A SUAVIDADE DO TOQUE

As Placas de Descarga THEA e KALI oferecem uma experiência única no seu espaço de banho.

O Soft Touch (disponível nas versões Branco e Preto) proporciona um toque aveludado e suave, e adiciona uma camada adicional ao conforto na utilização. Amplifica a estética e oferece uma resistência duradoura.

THE SOFTNESS OF THE TOUCH

THEA and KALI Flush Plates offer a unique experience in your bathroom space.

Soft Touch (available in White and Black versions) provides a velvety, soft touch and adds an additional layer of comfort in use. Amplifies aesthetics and offers long-lasting resistance.

LA SUAVIDAD DEL TACTO

Los pulsadores THEA y KALI ofrecen una experiencia única en tu espacio de baño.

Soft Touch (disponible en versiones Blanco y Negro) proporciona un tacto suave y aterciopelado y añade una capa adicional de comodidad en su uso. Amplifica la estética y ofrece una resistencia duradera.

LA DOUCEUR DU TOUCHER

Les plaques de commande THEA et KALI offrent une expérience unique dans votre espace de salle de bain.

Soft Touch (disponible en versions Blanc et Noir) offre un toucher velouté et doux et ajoute une couche supplémentaire de confort d'utilisation. Amplifie l'esthétique et offre une résistance durable.



Blair



escovado · cepillado
brushed · brossé

Kali

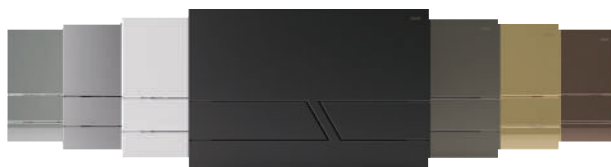

Thea



Orix



Lyra





clesi

Placas de comando

Pulsadores
Flush plates
Plaques de commande

Blair

Elegância e Funcionalidade numa peça única

Elegancia y Funcionalidad en una pieza única
Elegance and Functionality in a unique piece
Élégance et fonctionnalité dans une pièce unique

Uma placa ultrafina, apenas 5 mm de espessura, que é produzida a partir de uma única peça de aço inoxidável, ultrarresistente para suportar o desgaste diário. Poderá escolher entre 5 cores distintas e ultramodernas, Inox, Preto, Grafite, Ouro e Bronze.

Un plato ultrafino, de tan solo 5 mm de espesor, que está fabricado a partir de una sola pieza de acero inoxidable, ultrarresistente para soportar el desgaste diario. Puedes elegir entre 5 colores distintos y ultramodernos, Acero Inoxidable, Negro, Grafito, Oro y Bronce.

Ultra-thin, just 5mm thick, which is produced from a single piece of stainless steel, ultra-resistant to withstand daily wear and tear. You can choose between 5 distinct and ultra-modern colors, Stainless Steel, Black, Graphite, Gold and Bronze.

Une plaque ultra fin, de seulement 5 mm d'épaisseur, fabriqué à partir d'une seule pièce d'acier inoxydable, ultra résistant pour résister à l'usure quotidienne. Vous avez le choix entre 5 couleurs distinctes et ultra-modernes, Acier Inox, Noir, Graphite, Or et Bronze.



inox escovado
acero cepillado
brushed stainless steel
inox brossé

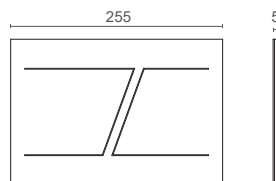

PVD



preto escovado
negro cepillado
brushed black
noir brossé



grafite escovado
grafito cepillado
brushed graphite
graphite brossé



ouro escovado
oro cepillado
brushed gold
or brossé



bronze escovado
bronce cepillado
brushed bronze
bronze brossé

REF.	acabamento · acabado · finish · finition				€
BK0202170	inox escovado · acero cepillado · stainless steel · acier inox	1	20	560	112,00
BK0202172	PVD preto escovado · negro cepillado · brushed black · noir brossé	1	20	560	154,00
BK0202174	PVD grafite escovado · grafito cepillado · brushed graphite · graphite brossé	1	20	560	154,00
BK0202176	PVD ouro escovado · oro cepillado · brushed gold · or brossé	1	20	560	154,00
BK0202178	PVD bronze escovado · bronce cepillado · brushed bronze · bronze brossé	1	20	560	154,00



ctesi

Kali

A placa de comando Kali destaca-se pela combinação harmoniosa dos botões e cores vibrantes com a simplicidade funcional. As linhas retas dos botões contribuem para uma estética minimalista e contemporânea.

El pulsador Kali destaca por la armoniosa combinación de pulsadores y colores vibrantes con sencillez funcional. Las líneas rectas de los botones contribuyen a una estética minimalista y contemporánea.

The Kali flush plate stands out for the harmonious combination of buttons and vibrant colors with functional simplicity. The straight lines of the buttons contribute to a minimalist and contemporary aesthetic.

La plaque de commande Kali se distingue par la combinaison harmonieuse de boutons et de couleurs vives avec une simplicité fonctionnelle. Les lignes droites des boutons contribuent à une esthétique minimaliste et contemporaine.

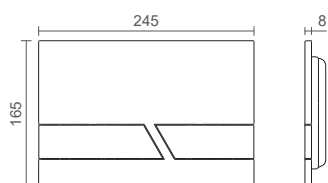

			SOFT TOUCH			PVD			
BRANCO	CROMADO	MATE	BRANCO MATE	PRETO MATE	GRAFITE MATE	OURO MATE	OURO	OURO ESCOVADO	BRONZE
branco	cromo	mate	branco mate	negro mate	grafito mate	oro mate	oro	oro cepillado	bronce
white	chrome	matte	matte white	matte black	matte graphite	matte gold	gold	brushed gold	bronze
blanc	chromé	mate	blanc mat	noir mat	graphite mat	or mat	or	or brossé	bronze
●	●	●	●	●	●	●	●	●	●

REF.	acabamento · acabado · finish · finition				€
BK0202150	branco · blanco · white · blanc	1	20	560	54,40
BK0202152	cromado · cromo · chromed · chrome	1	20	560	70,60
BK0202153	mate · mate · matte · mate	1	20	560	70,60
BK0202157	soft touch branco mate · blanco mate · matte white · blanc mat	1	20	560	76,40
BK0202151	soft touch preto mate · negro mate · matte black · noir mat	1	20	560	76,40
BK0202156	soft touch grafite mate · grafito mate · matte graphite · graphite mat	1	20	560	76,40
BK0202159	soft touch ouro mate · oro mate · matte gold · or mat	1	20	560	76,40
BK0202154	PVD ouro · oro · gold · or	1	20	560	136,00
BK0202158	PVD ouro escovado · oro cepillado · brushed gold · or brossé	1	20	560	136,00
BK0202155	PVD bronze · bronce · bronze · bronze	1	20	560	136,00



Orix

A placa de comando Orix caracteriza-se por botões retangulares, com zona de pressão ovalada, concebida para facilitar a utilização, aliando ergonomia a uma estética contemporânea.

El pulsador Orix se caracteriza por sus botones rectangulares, con una zona de presión ovalada, diseñada para facilitar el uso, combinando ergonomía con una estética contemporánea.

The Orix flush plate is characterised by rectangular buttons with an oval pressure area, designed to facilitate use while combining ergonomics with a contemporary aesthetic.

La plaque de commande Orix se caractérise par des boutons rectangulaires dotés d'une zone de pression ovale, conçue pour faciliter l'utilisation, alliant ergonomie et esthétique contemporaine.

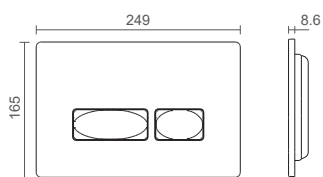
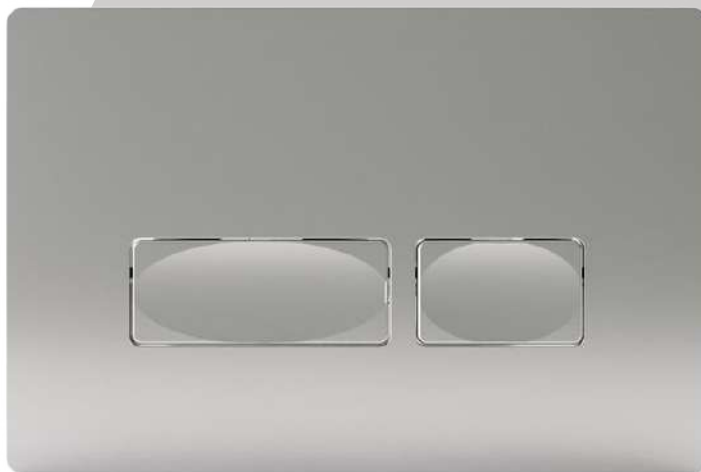

CROMADO
cromo
chrome
chrome





BRANCO MATE
blanco mate
matte white
blanc mat



PRETO MATE
negro mate
matte black
noir mat



REF.	acabamento · acabado · finish · finition				€
BK0202202	cromado · cromo · chrome · chrome	1	20	560	62,60
BK0202207	branco mate · blanco mate · matte white · blanc mat	1	20	560	62,60
BK0202201	preto mate · negro mate · matte black · noir mat	1	20	560	62,60



Thea

A placa de comando Thea destaca-se pelos botões redondos, de estética orgânica e contemporânea, que evocam o ciclo da água, promovendo harmonia e interação funcional.

El pulsador Thea se destaca por sus botones redondos, de estética orgánica y contemporánea, que evocan el ciclo del agua, promoviendo armonía e interacción funcional.

Thea Flush Plate stands out for its round buttons, featuring an organic and contemporary design that evokes the water cycle, promoting harmony and functional interaction.

La plaque de commande Thea se distingue par ses boutons ronds, à l'esthétique organique et contemporaine, évoquant le cycle de l'eau et favorisant harmonie et interaction fonctionnelle.

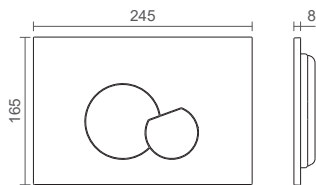
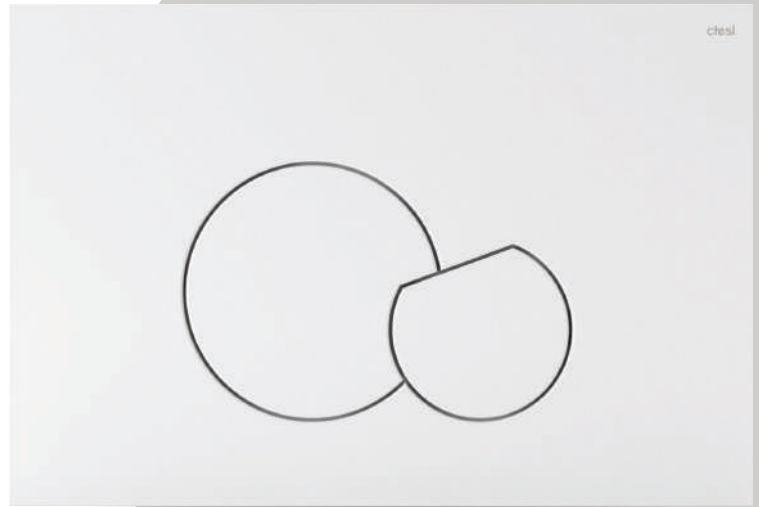

SOFT TOUCH

PVD

BRANCO blanco white blanc	CROMADO cromo chrome chromé	MATE mate matte mate	BRANCO MATE blanco mate matte white blanc mat	PRETO MATE negro mate matte black noir mat	GRAFITE MATE grafito mate matte graphite graphite mat	OURO MATE oro mate matte gold or mat	OURO oro gold or	OURO ESCOVADO oro cepillado brushed gold or brossé	BRONZE bronce bronze bronze

REF.	acabamento · acabado · finish · finition				€
BK0202160	branco · blanco · white · blanc	1	20	560	54,40
BK0202162	cromado · cromo · chromed · chrome	1	20	560	70,60
BK0202163	mate · mate · matte · mate	1	20	560	70,60
BK0202167	soft touch branco mate · blanco mate · matte white · blanc mat	1	20	560	76,40
BK0202161	soft touch preto mate · negro mate · matte black · noir mat	1	20	560	76,40
BK0202166	soft touch grafite mate · grafito mate · matte graphite · graphite mat	1	20	560	76,40
BK0202169	soft touch ouro mate · oro mate · matte gold · or mat	1	20	560	76,40
BK0202164	PVD ouro · oro · gold · or	1	20	560	136,00
BK0202168	PVD ouro escovado · oro cepillado · brushed gold · or brossé	1	20	560	136,00
BK0202165	PVD bronze · bronce · bronze · bronze	1	20	560	136,00



clesì

Lyra

A placa de comando Lyra destaca-se pelos botões redondos, que conferem uma estética suave e contemporânea, inspirada no ciclo natural da água e na harmonia dos espaços.

El pulsador Orix se caracteriza por sus botones rectangulares, con una zona de presión ovalada, diseñada para facilitar el uso, combinando ergonomía con una estética contemporánea.

The Lyra flush plate stands out for its round buttons, which give it a soft and contemporary aesthetic, inspired by the natural water cycle and the harmony of spaces.

La plaque de commande Lyra se distingue par ses boutons ronds, qui lui confèrent une esthétique douce et contemporaine, inspirée du cycle naturel de l'eau et de l'harmonie des espaces.

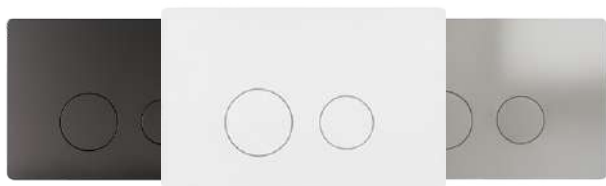
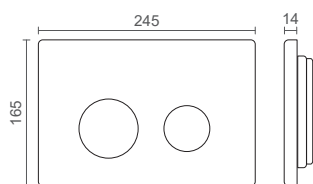
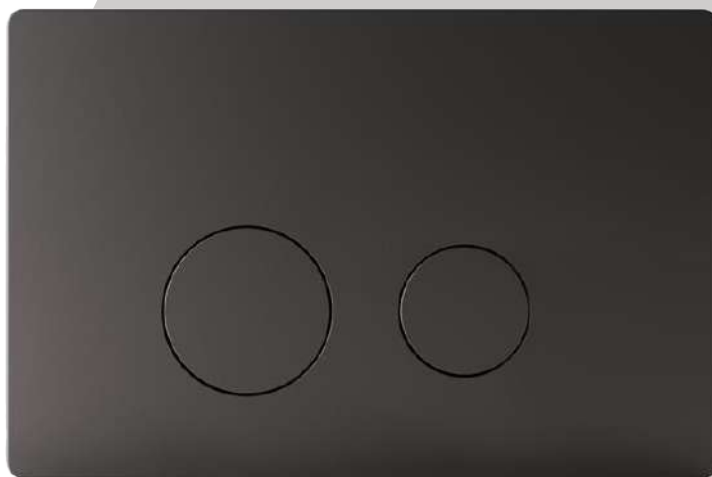

CROMADO
cromo
chrome
chrome



BRANCO MATE
blanco mate
matte white
blanc mat



PRETO MATE
negro mate
matte black
noir mat



REF.	acabamento · acabado · finish · finition				€
BK0202302	cromado · cromo · chrome · chrome	1	20	560	62,60
BK0202307	branco mate · blanco mate · matte white · blanc mat	1	20	560	62,60
BK0202301	preto mate · negro mate · matte black · noir mat	1	20	560	62,60

Acessórios · Accesorios
Accessoires · Accessoires



Slim				
REF.			☞	€
P7123030	válvula descarga válvula de salida flushing valve mécanisme de chasse		1	21,50



Kompact				
REF.			☞	€
P8120014	torneira boia válvula de entrada float valve robinet flotteur		1	19,20



Aumento Adaptador Adapter Adaptateur				
REF.			☞	€
P6050017	D90/110		1	5,30



Conjunto de tubos direitos e kit de fixação Manguitos inodoro y kit fijación Assembly of straight tubes and fixing kit Kit d'assemblage de tubes droits et de fixation				
REF.			☞	€
P7050103	180 mm		1	13,60



Conjunto de tubos excêntricos Manguitos inodoro excêntricos Eccentric tube assembly Assemblage de tube excentrique				
REF.			☞	€
BK1001000	180 mm		1	62,80



Kit de prolongamento tubos direitos
 Kit extensión manguitos inodoro y fijación
 Straight pipe extension kit
 Kit d'extension de tuyau droit

REF.			€
BK1001010	350mm	1	19,40



Curva descarga
 Codo de salida
 Toilet connecting pipe
 Tube de raccordement de toilette

REF.	mm		€
P6050016	D90x350	1	14,60



Forquilha slim self duplo
 Codo de salida doble
 Double elbow
 Coude double

REF.	mm		€
P7050113	D90	1	27,80

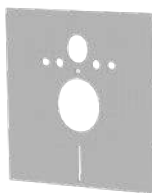

Placa de isolamento
 Placa de aislamiento
 Insulation plate
 Plaque isolante

REF.			€
BK1001020	sanita/bidé · inodoro/bidé toilet/bidet · toilette/bidet	1	9,20



Kit fixação slim solid
 Kit fijación slim solid
 Slim solid fixing kit
 Kit de fixation

REF.			€
BK1001030	fixação canto · fijación esquina corner fixing · fixation d'angle	1	24,50

Autoclismos exteriores · Cisternas adosadas Exposed cisterns · Réservoirs apparents

Monobloco

Para aplicação acoplada diretamente sobre a sanita. Ideal para a substituição de autoclismos cerâmicos.

Mochila

Para aplicação com fixação na parede, fornecido com tubo de descarga para ligação e limpeza da sanita.

Alto

Para aplicação com fixação em posição alta na parede, fornecido com tubo de descarga até 1,60m de altura e puxador para accionamento da descarga para a limpeza de sanitas ou sanitas turcas.

Cisterna Baja

Para una instalación acoplada, la cisterna se coloca directamente en el inodoro. Ideal para sustituir cisternas de cerámica.

Posición Media-baja

Para una instalación de montaje en la pared, con un tubo de descarga que se conecta al inodoro.

Posición Alta

Para una instalación de montaje en pared alta, con una tubería de descarga larga y una manilla para hacer la descarga.

Close Coupled

For a close coupled installation, the cistern is placed directly in the toilet pan. Ideal for replacing ceramic cisterns.

Medium-low Position

For a wall mounting installation, provided with flush pipe that connects to the toilet pan.

High Position

For a high, wall mounted installation, provided with a long flush pipe up to 1.60m in height and a pull handle for flushing the cistern or for squat pan.

Réservoir Attenant

Pour une application couplée directement sur la cuvette. Idéal pour remplacer des cuvettes céramiques.

Réservoir Semi-bas

Pour fixation au mur, fournie avec tube de chasse pour la nettoyage des cuvettes.

Réservoir Haut

Pour une application de fixation au mur en haute position à chaînette, fournit avec tube de chasse jusqu'à 1,60 m de hauteur haut pour la nettoyage des cuvettes ou pour WC à la turque.



Ondabloc

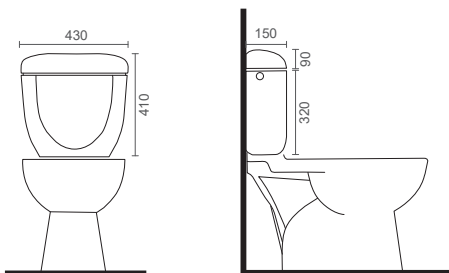

CARACTERÍSTICAS

- Descarga dupla (3/6 litros)
- Fácil regulação do volume de descarga máxima até 9l
- Sistema de montagem para instalação acoplada à sanita
- Entrada de água lateral (esquerda/direita) ou inferior e posterior
- Isolamento anti-condensação e acústico
- Inclui todos os acessórios necessários para instalação
- Válvula de descarga com vedante em silicone
- Em conformidade com a norma europeia (EN14055)

CARACTERÍSTICAS



- Doble descarga (3/6 litros)
- Ajuste fácil del volumen máximo de descarga hasta 9l
- Entrada de agua lateral (izquierda / derecha) o inferior y posterior
- Sistema de montaje que une de forma segura la cisterna al inodoro
- Anti-condensación y aislamiento acústico
- Incluye todos los accesorios para la instalación
- Válvula de descarga con junta de silicona
- De acuerdo con la normativa europea (EN14055)

FEATURES

- Dual flush (3/6 liters)
- Maximum flush volume adjustment up to 9l
- Side (left / right) or bottom and rear water inlet
- Mounting system that securely couples cistern to toilet
- Anti-condensation and acoustic isolation
- Includes all installation accessories
- Flush valve with silicon seal
- In accordance with european standard (EN14055)

CARACTÉRISTIQUES

- Double débit (3/6 litres)
- Réglage facile du volume maximal de la décharge jusqu'à 9l
- Alimentation de l'eau latéral ou à la bas (gauche / droite)
- Système de montage couplé à la cuvette
- Isolement anti condensation et accoustique
- Accessoires pour installation inclus
- Soupape de décharge avec joint du silicone
- En conformité avec la norme européenne (EN14055)

REF.					€
BK0010500	branco - 3/8" · blanco 3/8"	1	4	80	64,80
BK0010501	white 3/8" · blanc 3/8"	1	4	80	68,50

Bahia Duo



3L
6L

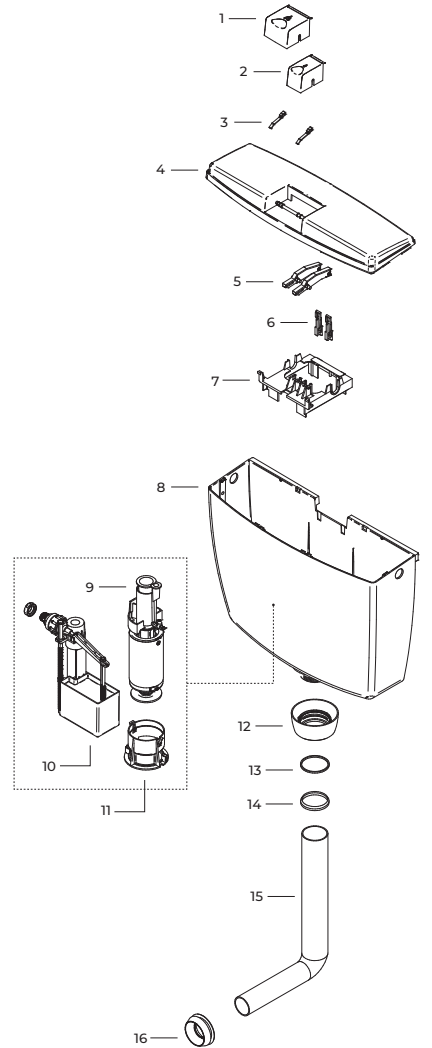
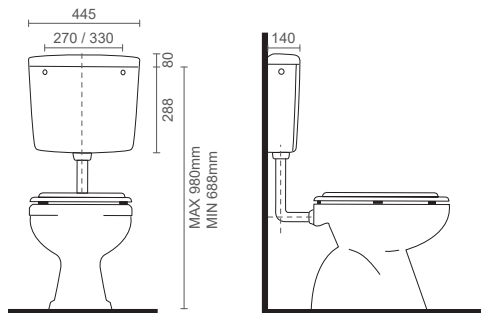

CARACTERÍSTICAS

- Descarga dupla (3/6 litros)
- Fácil regulação do volume de descarga máxima até 9l
- Entrada de água lateral (esquerda/direita) e posterior
- Isolamento anti-condensação e acústico
- Inclui todos os acessórios necessários para instalação
- Válvula de descarga com vedante em silicone
- Com tubo de descarga Ø50 x Ø40 x 325 mm
- Em conformidade com a norma europeia (EN14055)

FEATURES

- Dual flush (3/6 liters)
- Maximum flush volume adjustment up to 9l
- Side (left/right) and rear water inlet
- Anti-condensation and acoustic isolation
- Includes all installation accessories
- Flush valve with silicon seal
- With flush pipe - Ø50 x Ø40 x 325mm
- According to EN14055 european standard

CARACTERÍSTICAS

- Descarga doble (3/6 litros)
- Ajuste fácil del volumen máximo de descarga hasta 9l
- Entrada de agua lateral (izquierda / derecha) y trasera
- Anti-condensación y aislamiento acústico
- Incluye todos los accesorios para la instalación
- Válvula de descarga con junta de silicona
- Con tubo de descarga - Ø50 x Ø40 x 325mm
- De acuerdo con la normativa europea (EN14055)

CARACTÉRISTIQUES

- Double débit (3/6 litres)
- Réglage facile du volume maximal de la décharge jusqu'à 9l
- Alimentation de l'eau latéral et postérieure
- Isolement anti condensation et accoustique
- Accessoires pour installation inclus
- Soupape de décharge avec joint du silicone
- Avec tube - Ø50 x Ø40 x 325mm
- Conformément à la norme européenne (EN14055)

REF.

BK0010100

branco - 3/8" · blanco 3/8"
white 3/8" · blanc 3/8"



€

1

5

100

50,00

Bahia

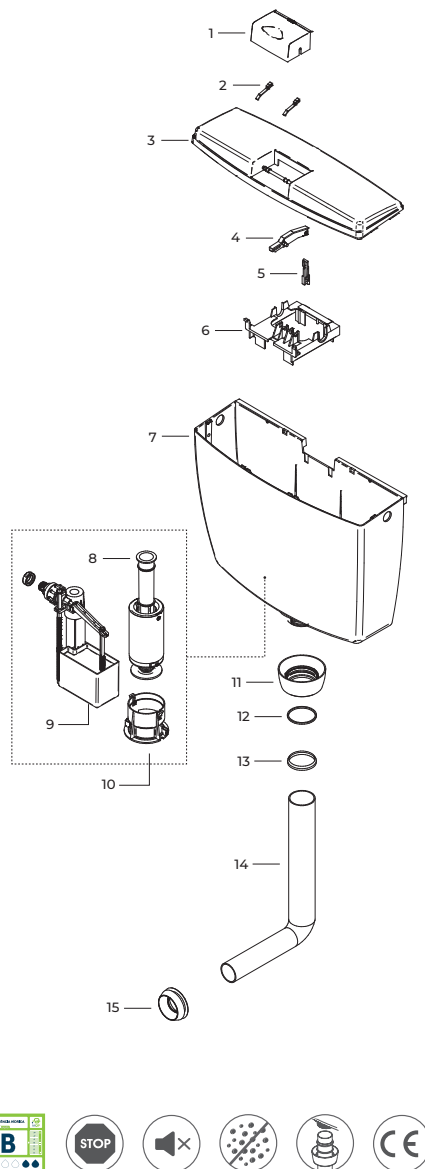
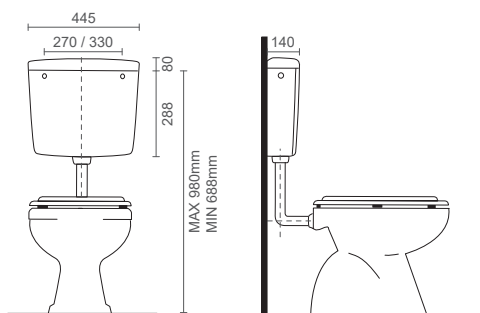

CARACTERÍSTICAS

- Descarga interrompível (até 6 litros)
- Fácil regulação do volume de descarga máxima entre 6 e 9l
- Entrada de água lateral (esquerda/direita) e posterior
- Isolamento anti-condensação e acústico
- Inclui todos os acessórios necessários para instalação
- Válvula de descarga com vedante em silicone
- Com tubo de descarga Ø50 x Ø40 x 325 mm
- Em conformidade com a norma europeia (EN14055)

FEATURES

- Interruptible flush until 6 liters
- Maximum flush volume adjustment between 6 and 9l
- Side (left/right) and rear water inlet
- Anti-condensation and acoustic isolation
- Includes all installation accessories
- Flush valve with silicon seal
- With flush pipe - Ø50 x Ø40 x 325mm
- According to EN14055 european standard

CARACTERÍSTICAS

- Descarga interrumpible hasta 6 litros
- Ajuste fácil del volumen máximo de descarga entre 6 y 9l
- Entrada de agua lateral (izquierda / derecha) y trasera
- Anti-condensación y aislamiento acústico
- Incluye todos los accesorios para la instalación
- Válvula de descarga con junta de silicona
- Con tubo de descarga - Ø50 x Ø40 x 325mm
- De acuerdo con la normativa europea (EN14055)

CARACTÉRISTIQUES

- Décharge interruptible à 6 litres
- Réglage facile du volume maximal de la décharge entre 6 et 9l
- Alimentation de l'eau latéral et postérieure
- Isolement anti condensation et accoustique
- Accessoires pour installation inclus
- Soupape de décharge avec joint du silicone
- Avec tube - Ø50 x Ø40 x 325mm
- Conformément à la norme européenne (EN14055)

REF.					€
BK0000400	branco - 3/8" · blanco 3/8" white 3/8" · blanc 3/8"	1	5	100	47,00

Iara Duo

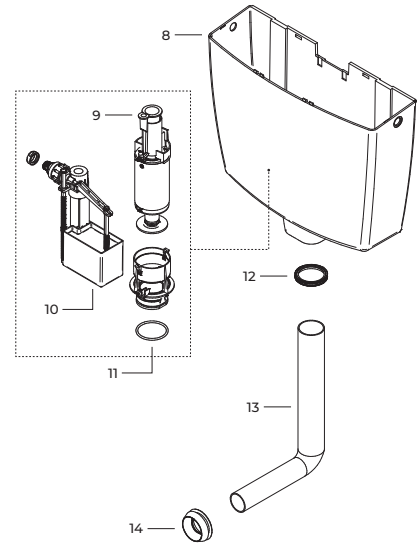
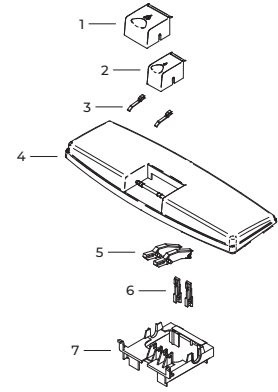
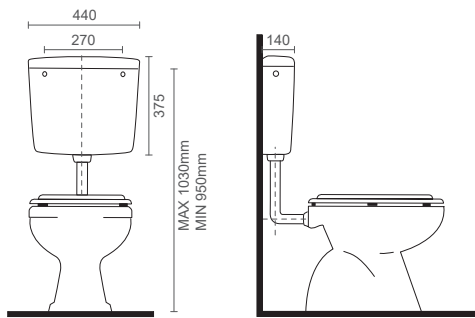

CARACTERÍSTICAS

- Descarga dupla (3/6 litros)
- Fácil regulação do volume de descarga máxima até 9l
- Sistema de encaixe rápido do tubo de descarga
- Entrada de água lateral (esquerda/direita) e posterior
- Isolamento anti-condensação e acústico
- Inclui todos os acessórios necessários para instalação
- Válvula de descarga com vedante em silicone
- Com tubo de descarga Ø50 x Ø40 x 325 mm
- Em conformidade com a norma europeia (EN14055)

FEATURES

- Dual flush (3/6 liters)
- Maximum flush volume adjustment up to 9l
- Quick flush pipe installation
- Side (left/right) and rear water inlet
- Anti-condensation and acoustic isolation
- Includes all installation accessories
- Flush valve with silicon seal
- With flush pipe - Ø50 x Ø40 x 325mm
- According to EN14055 european standard

CARACTERÍSTICAS

- Descarga doble (3/6 litros)
- Ajuste fácil del volumen máximo de descarga hasta 9l
- Rápida instalación del tubo de descarga
- Entrada de agua lateral (izquierda / derecha) y trasera
- Anti-condensación y aislamiento acústico
- Incluye todos los accesorios para la instalación
- Válvula de descarga con junta de silicona
- Con tubo de descarga - Ø50 x Ø40 x 325mm
- De acuerdo con la normativa europea (EN14055)

CARACTÉRISTIQUES

- Double débit (3/6 litres)
- Réglage facile du volume maximal de la décharge jusqu'à 9l
- Montage rapide du tube de décharge
- Alimentation de l'eau latéral et postérieure
- Isolement anti condensation et accoustique
- Accessoires pour installation inclus
- Soupape de décharge avec joint du silicon
- Avec tube Ø50 x Ø40 x 325mm
- Conformément à la norme européenne (EN14055)

REF.

REF.	cores · colores colors · couleurs
BK0010000	3/8" branco · blanco · white · blanc
BK0010001	3/8" cinzento · gris · gray · gris
BK0010002	3/8" pergamón
BK0010003	3/8" rosa · rosa · pink · rose

cores · colores colors · couleurs

	1	5	100	€
	1	5	100	48,50
	1	5	100	52,50
	1	5	100	52,50
	1	5	100	52,50

Iara

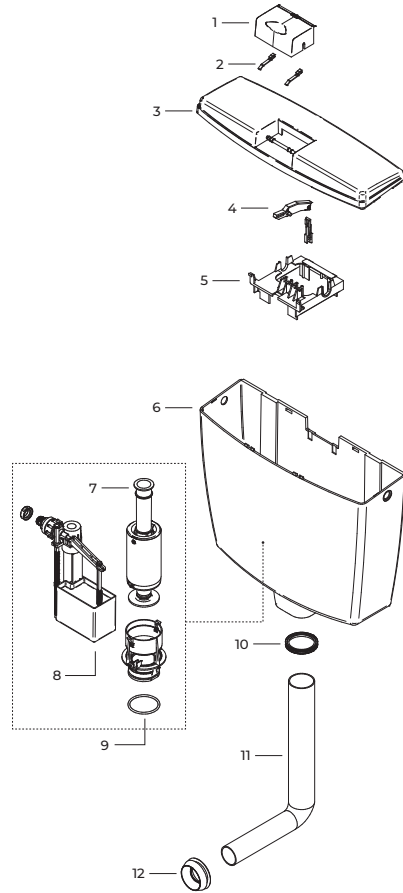
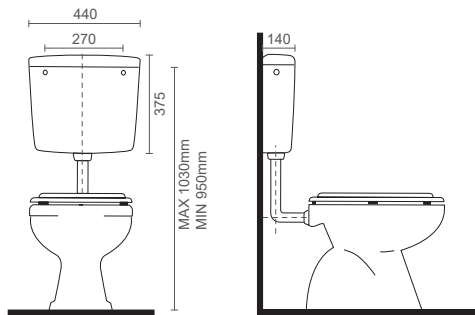

CARACTERÍSTICAS

- Descarga interrompível (até 6 litros)
- Fácil regulação do volume de descarga máxima entre 6l e 9l
- Sistema de encaixe rápido do tubo de descarga
- Entrada de água lateral (esquerda/direita) e posterior
- Isolamento anti-condensação e acústico
- Inclui todos os acessórios necessários para instalação
- Válvula de descarga com vedante em silicone
- Com tubo de descarga Ø50 x Ø40 x 325 mm
- Em conformidade com a norma europeia (EN14055)

FEATURES

- Interruptible flush until 6 liters
- Maximum flush volume adjustment between 6 and 9 l
- Quick flush pipe installation
- Side (left/right) and rear water inlet
- Anti-condensation and acoustic isolation
- Includes all installation accessories
- Flush valve with silicon seal
- With flush pipe Ø50 x Ø40 x 325mm
- According to EN14055 european standard

CARACTERÍSTICAS

- Descarga interrumpible hasta 6 litros
- Ajuste fácil del volumen máximo de descarga entre 6 y 9 l
- Rápida instalación del tubo de descarga
- Entrada de agua lateral (izquierda / derecha) y trasera
- Anti-condensación y aislamiento acústico
- Incluye todos los accesorios para la instalación
- Válvula de descarga con junta de silicona
- Con tubo de descarga Ø50 x Ø40 x 325mm
- De acuerdo con la normativa europea (EN14055)

CARACTÉRISTIQUES

- Décharge interrompible à 6 litres
- Réglage facile du volume maximal de la décharge entre 6 et 9 l
- Montage rapide du tube de décharge
- Alimentation de l'eau latéral et postérieure
- Isolement anti condensation et accoustique
- Accessoires pour installation inclus
- Soupape de décharge avec joint du silicone
- Avec tube Ø50 x Ø40 x 325mm
- Conformément à la norme européenne (EN14055)

REF.

BK0000300

branco - 3/8" · blanco 3/8"
white 3/8" · blanc 3/8"



 €
 1 5 100 45,50

Trópico

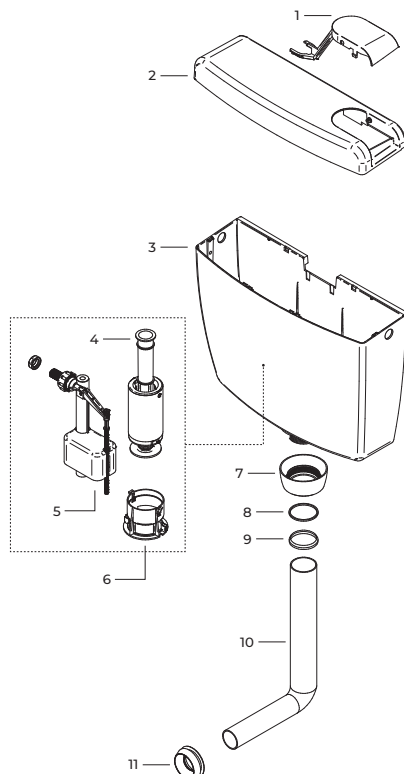
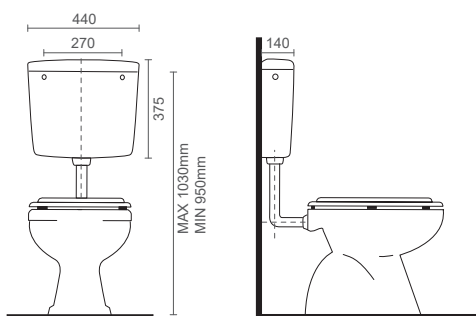

CARACTERÍSTICAS

- Descarga interrompível (até 6 litros)
- Fácil regulação do volume de descarga máxima entre 6l e 9l
- Entrada de água lateral (esquerda/direita) e posterior
- Inclui todos os acessórios necessários para instalação
- Válvula de descarga com vedante em silicone
- Com tubo de descarga Ø50 x Ø40 x 325 mm
- Em conformidade com a norma europeia (EN14055)

FEATURES

- Interruptible flush until 6 liters
- Maximum flush volume adjustment between 6 and 9l
- Side (left/right) and rear water inlet
- Includes all installation accessories
- Flush valve with silicon seal
- With flush pipe Ø50 x Ø40 x 325mm
- According to EN14055 european standard

CARACTERÍSTICAS

- Descarga interrumpible hasta 6 litros
- Ajuste fácil del volumen máximo de descarga entre 6 y 9l
- Entrada de agua lateral (izquierda / derecha) y trasera
- Incluye todos los accesorios para la instalación
- Válvula de descarga con junta de silicona
- Con tubo de descarga Ø50 x Ø40 x 325mm
- De acuerdo con la normativa europea (EN14055)

CARACTÉRISTIQUES

- Décharge interruptible à 6 litres
- Réglage facile du volume maximal de la décharge entre 6 et 9l
- Alimentation de l'eau latéral et postérieure
- Accessoires pour installation inclus
- Soupape de décharge avec joint du silicone
- Avec tube Ø50 x Ø40 x 325mm
- Conformément à la norme européenne (EN14055)

REF.

BK0000100

branco - 3/8" · blanco 3/8"
white 3/8" · blanc 3/8"



€

1

5

100

38,00

Trópico alto

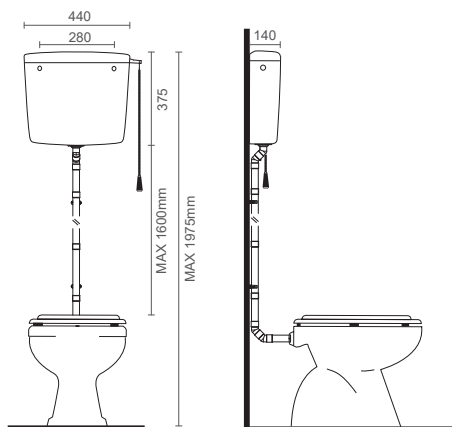
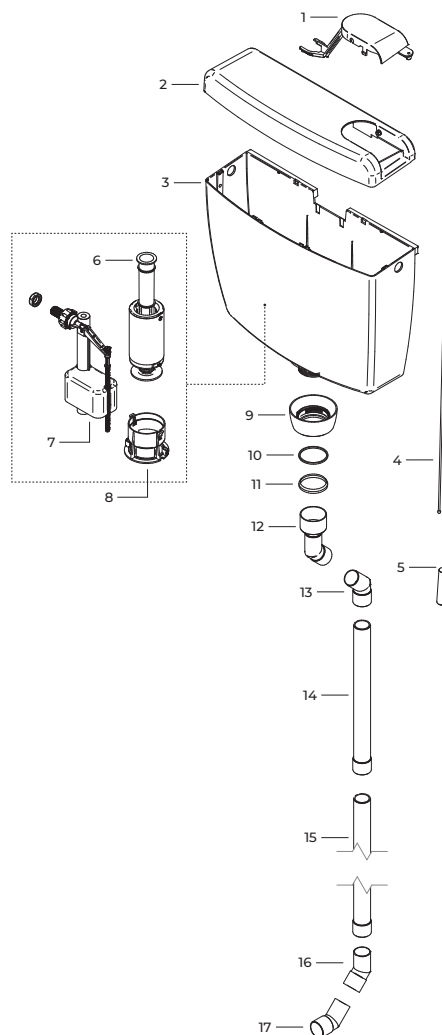

CARACTERÍSTICAS

- Fácil regulação do volume de descarga máxima entre 6l e 9l
- Entrada de água lateral (esquerda/direita) e posterior
- Inclui todos os acessórios necessários para instalação
- Válvula de descarga com vedante em silicone
- Fornecido c/ kit de tubos de descarga: 4 tubos - Ø50 x Ø32,5 x 400 mm
- Em conformidade com a norma europeia (EN14055)

FEATURES

- Maximum flush volume adjustment between 6 and 9l
- Side (left) and rear water inlet
- Includes all installation accessories
- Flush valve with silicon seal
- Provided with flush pipe kit: 4 pipes - Ø50 x Ø32,5 x 400mm
- According to EN14055 european standard

CARACTERÍSTICAS

- Ajuste fácil del volumen máximo de descarga entre 6 y 9 l
- Entrada de agua izquierda y trasera
- Incluye todos los accesorios para la instalación
- Válvula de descarga con junta de silicona
- Equipado con un juego de 4 tubos - Ø50 x Ø32,5 x 400mm
- De acuerdo con la normativa europea (EN14055)

CARACTÉRISTIQUES

- Réglage facile du volume maximal de la décharge entre 6 et 9l
- Alimentation de l'eau latéral (à la gauche) et postérieure
- Accessoires pour installation inclus
- Soupape de décharge avec joint du silicone
- Fournit avec ensemble de tubes: 4 tubes - Ø50 x Ø32,5 x 400mm
- Conformément à la norme européenne (EN14055)

REF.

BK0000150

3/8" branco c/ tubo · blanco c/ tubo
white w/ tube · blanc a/ tube

1 5 100 49,50 €

Ioca

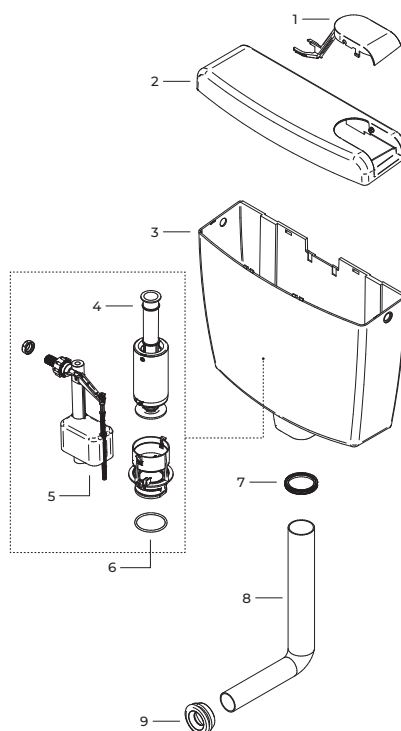
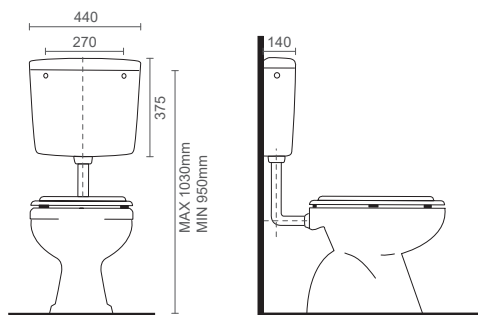

CARACTERÍSTICAS

- Descarga interrompível (até 6 litros)
- Fácil regulação do volume de descarga máxima entre 6l e 9l
- Sistema de encaixe rápido do tubo de descarga
- Entrada de água lateral (esquerda/direita) e posterior
- Inclui todos os acessórios necessários para instalação
- Válvula de descarga com vedante em silicone
- Com tubo de descarga Ø50 x Ø40 x 325 mm
- Em conformidade com a norma europeia (EN 14055)

FEATURES

- Interruptible flush until 6 liters
- Maximum flush volume adjustment between 6 and 9l
- Quick flush pipe installation
- Side (left/right) and rear water inlet
- Includes all installation accessories
- Flush valve with silicon seal
- With flush pipe Ø50 x Ø40 x 325mm
- According to EN14055 european standard

CARACTERÍSTICAS

- Descarga interrumpible hasta 6 litros
- Ajuste fácil del volumen máximo de descarga entre 6 y 9l
- Rápida instalación del tubo de descarga
- Entrada de agua lateral (izquierda / derecha) y trasera
- Incluye todos los accesorios para la instalación
- Válvula de descarga con junta de silicona
- Con tubo de descarga Ø50 x Ø40 x 325mm
- De acuerdo con la normativa europea (EN14055)

CARACTÉRISTIQUES

- Décharge interrumpible à 6 litres
- Réglage facile du volume maximal de la décharge entre 6 et 9l
- Montage rapide du tube de décharge
- Alimentation de l'eau latéral et postérieure
- Accessoires pour installation inclus
- Soupape de décharge avec joint du silicone
- Avec tube Ø50 x Ø40 x 325mm
- Conformément à la norme européenne (EN14055)

REF.

BK000001

branco - 3/8" · blanco 3/8"
white 3/8" · blanc 3/8"

1 5 100 €

1 5 100 36,00

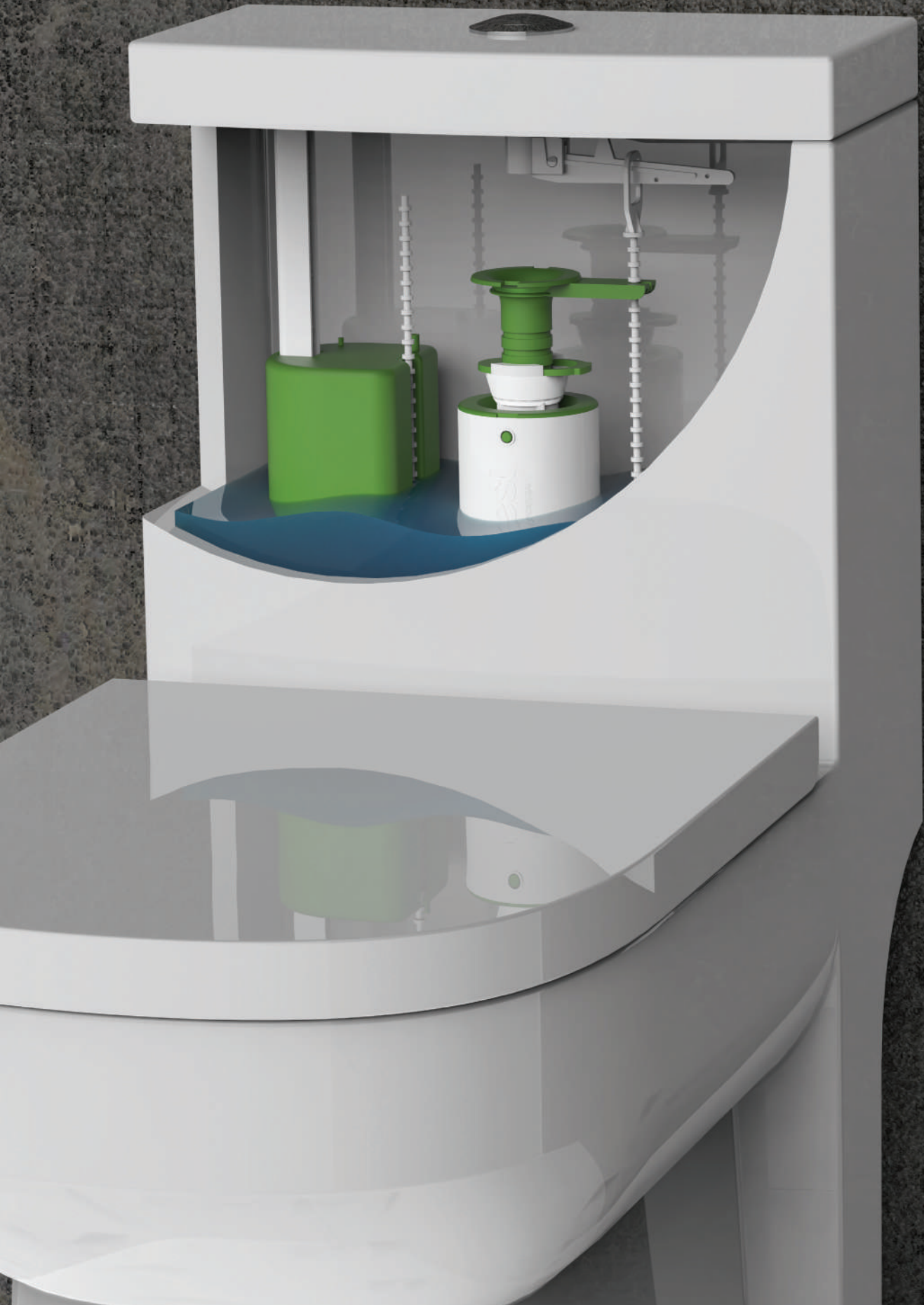

Kombi

Fecho rápido e eficaz
Cierre rápido y efectivo
Fast and effective closing
Fermeture rapide et efficace

Fácil ajuste da boia em altura
Ajuste fácil de altura
Easy height adjustment
Réglage facile de la hauteur

2 em
en
in
en **1**

Entrada inferior ou entrada lateral
Entrada inferior o entrada lateral
Bottom entry or side entry
Entrée à la bas ou entrée latérale

Compacta

Compacta · Compact · Compacte

Ideal para autoclismos de dimensões reduzidas
Ideal para cisternas pequeñas
Ideal for small flushing cisterns
Idéal pour les petits réservoirs de chasse

Universal

Adapta-se facilmente a todos os autoclismos cerâmicos
Fácilmente adaptable a todas las cisternas de cerámica
Easily adapts to all ceramic cisterns
Facilement adaptable à tous les réservoirs en céramique

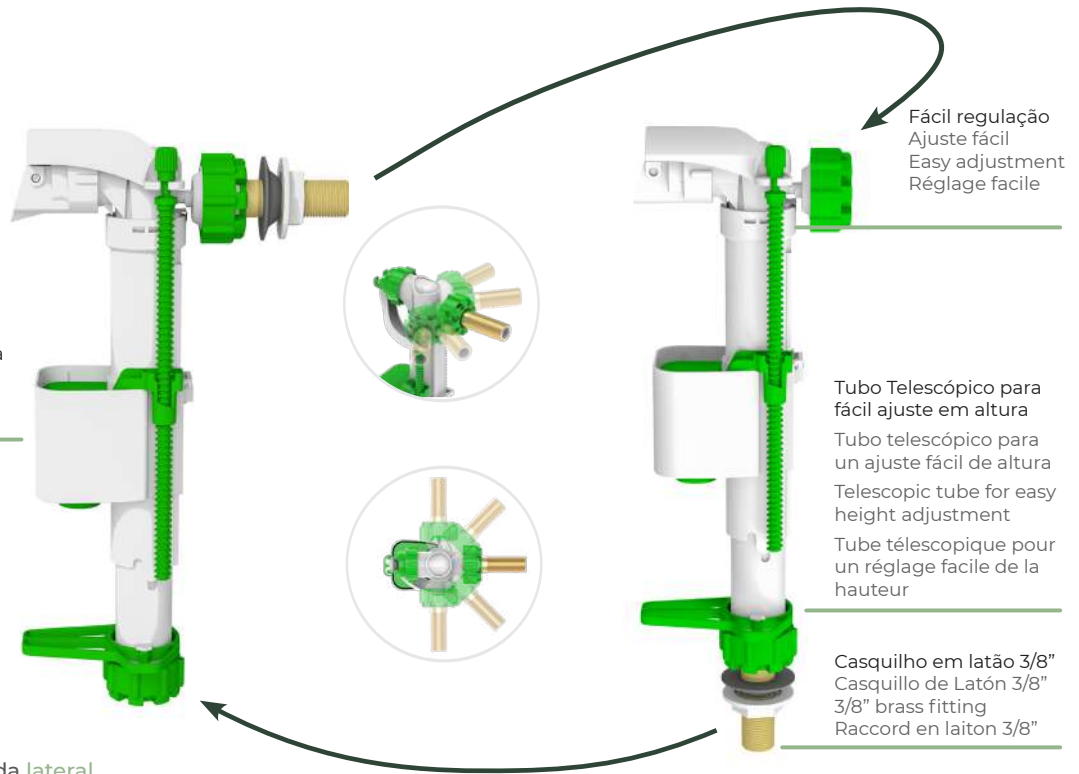

Fácil regulação
Ajuste fácil
Easy adjustment
Réglage facile

Tubo Telescópico para fácil ajuste em altura
Tubo telescópico para un ajuste fácil de altura
Telescopic tube for easy height adjustment
Tube télescopique pour un réglage facile de la hauteur

Casquilho em latão 3/8"
Casquillo de Latón 3/8"
3/8" brass fitting
Raccord en laiton 3/8"

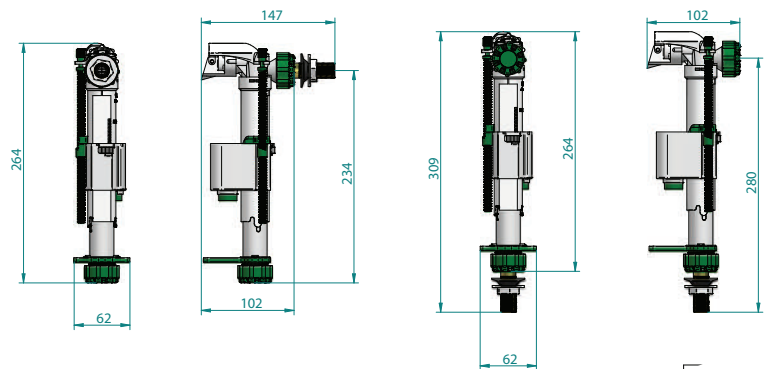

CARACTERÍSTICAS

- Fácil ajuste em altura
- Entrada lateral orientável a 180°
- Enchimento rápido e silencioso
- Excelente desempenho com qualquer pressão de rede
- Sistema de entrada de água ultra-silencioso
- Casquilho em latão
- Fácil adaptação para torneira de boia de entrada de água lateral ou inferior

FEATURES

- Easy height adjustment
- 180° swiveling side inlet
- Fast and quiet filling
- Excellent performance in low or high pressure
- Ultra quiet water inlet system
- Brass fitting
- Easy adaptation to side or bottom water inlet float valve

CARACTERÍSTICAS

- Ajuste fácil de altura
- Entrada lateral giratoria 180°
- Llenado rápido y silencioso
- Excelente desempeño en baja o alta presión
- Sistema de entrada de agua ultra silencioso
- Casquillo de latón
- Fácil adaptación del flotador para entrada de agua lateral o inferior

CARACTÉRISTIQUES

- Réglage facile de la hauteur
- Entrée latérale rotative à 180°
- Remplissage rapide et silencieux
- Excellentes performances à basse ou haute pression
- Système d'entrée d'eau ultra-silencieux
- Raccord en laiton
- Facile adaptation à robinet à flotteur d'entrée d'eau latérale ou à la bas

REF.

BK0402000

3/8"

5 20 320 €

5 20 320 17,40

Kompact

Fecho rápido e eficaz
Cierre rápido y efectivo
Fast and effective closing
Fermeture rapide et efficace

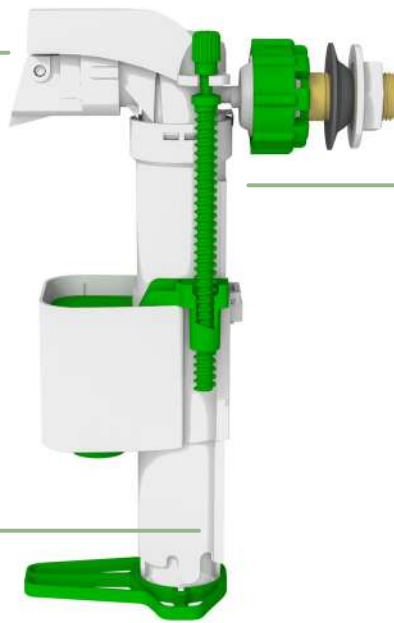

Fácil regulação
Ajuste fácil
Easy adjustment
Réglage facile

Fácil ajuste da boia em altura
Ajuste fácil de altura
Easy height adjustment
Réglage facile de la hauteur

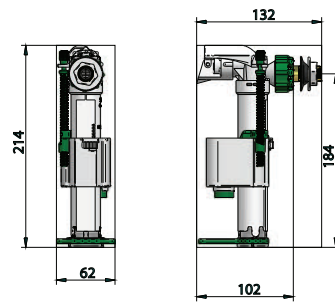
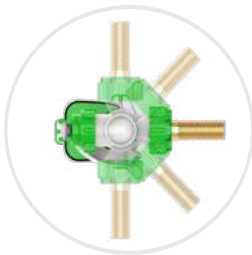

CARACTERÍSTICAS

- Fácil ajuste em altura
- Entrada lateral orientável a 180°
- Enchimento rápido e silencioso
- Excelente desempenho com qualquer pressão de rede
- Sistema de entrada de água ultra-silencioso
- Casquilho em latão

FEATURES

- Easy height adjustment
- 180° swiveling side inlet
- Fast and quiet filling
- Excellent performance in low or high pressure
- Ultra quiet water inlet system
- Brass fitting

CARACTERÍSTICAS

- Ajuste fácil de altura
- Entrada lateral giratoria 180°
- Llenado rápido y silencioso
- Excelente desempeño en baja o alta presión
- Sistema de entrada de agua ultra silencioso
- Casquillo de latón

CARACTÉRISTIQUES

- Réglage facile de la hauteur
- Entrée latérale rotative à 180°
- Remplissage rapide et silencieux
- Excellentes performances à basse ou haute pression
- Système d'entrée d'eau ultra-silencieux
- Raccord en laiton

REF.

BK0400100

3/8"



€

5

20

320

16,40

Bi-flash

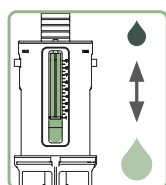
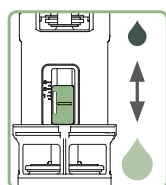
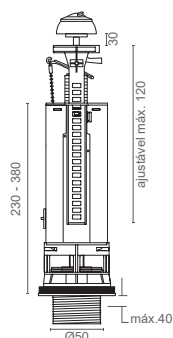

AJUSTE PARA CIMA PARA
DESCARREGAR MENOS ÁGUA

AJUSTAR HACIA ARRIBA PARA
REDUCIR LA DESCARGA DE AGUA

ADJUST UPWARDS TO REDUCE
WATER FLUSH

AJUSTEZ VERS LE HAUT POUR
RÉDUIRE LE DÉBIT DE L'EAU



- Válvula de dupla descarga para autoclismos cerâmicos
- Botão cromado para aplicação universal
- Fácil regulação do volume de descarga máximo
- Fácil regulação do volume da meia descarga
- Fácil e rápida instalação e ajuste em altura
- Botão ajustável em altura
- Inclui parafusos de fixação em aço inox para cisterna

- Válvula de descarga doble para cisterna de cerámica
- Botón cromado para aplicación universal
- Ajuste fácil del volumen máximo de descarga
- Ajuste fácil del volumen de media descarga
- Instalación fácil y rápida y altura ajustable
- Altura ajustable del botón
- Incluye tornillos de montaje de acero inoxidable para cisterna

- Dual flush valve for ceramic cistern
- Chromed button for universal application
- Easy maximum discharge volume adjustment
- Easy half discharge volume adjustment
- Easy and quick installation with adjustable height
- Adjustable button height
- Includes cistern stainless steel mounting screws

- Mécanisme de double débit pour réservoir céramique
- Bouton chromé pour une application universelle
- Réglage facile du volume de décharge maximale
- Réglage facile de la moitié du volume de décharge
- Installation facile et rapide et hauteur ajustable
- Bouton hauteur réglable
- Inclut vis de fixations en acier inox pour réservoir

REF.				€
BK0410510	dupla descarga · descarga doble dual flush · double chasse	5	20	19,40

Duo

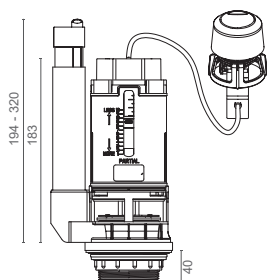

- Válvula de dupla descarga para autoclismos cerâmicos
- Botão cromado
- Fácil e rápida instalação e ajuste em altura
- Descarga regulável
- Posicionamento de botão ajustável para todo o tipo de cisternas
- Inclui parafusos de fixação em aço inox para cisterna

- Válvula de descarga doble para cisterna de cerámica
- Botón cromado
- Instalación fácil y rápida y altura ajustable
- Flujo ajustable
- Posición de botón ajustable para cualquier tipo de cisterna
- Incluye tornillos de montaje de acero inoxidable para cisterna

- Dual flush valve for ceramic cistern
- Chromed button
- Easy and quick installation with adjustable height
- Adjustable flow
- Adjustable button position for any kind of cistern
- Includes cistern stainless steel mounting screws

- Mécanisme de double débit pour réservoir céramique
- Bouton chromé
- Installation facile et rapide et hauteur ajustable
- Débit réglable
- Positionnement du bouton réglable pour tous les types de réservoirs
- Inclut vis de fixations en acier inox pour réservoir

REF.				€
BK0410500	dupla descarga · descarga doble dual flush · double chasse	5	20	19,40

Press

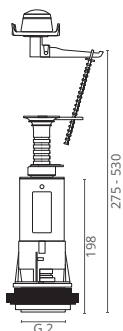

- Válvula de descarga simples para autoclismos cerâmicos
- Botão de premir cromado
- Fácil e rápida instalação e ajuste em altura
- Posicionamento de botão ajustável
- Inclui parafusos de fixação em aço inox para cisterna

- Válvula de descarga para cisterna de cerâmica
- Pulsador cromado
- Instalación fácil y rápida y altura ajustable
- Posición de botón ajustable
- Incluye tornillos de acero inoxidable de montaje para cisterna

- Single flush valve for ceramic cistern
- Chromed press button
- Easy and quick installation with adjustable height
- Adjustable button position
- Includes cistern stainless steel mounting screws

- Mécanisme de simple débit pour réservoir céramique
- Bouton de pousser chromé
- Installation facile et rapide et hauteur ajustable
- Positionnement du bouton réglable
- Inclut vis de fixations en acier pour réservoir

REF.				€
BK0410000	start / stop	5	20	17,00

Pull

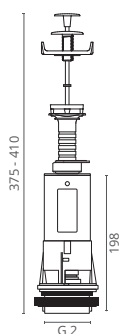

- Válvula de descarga simples para autoclismos cerâmicos
- Botão de puxar cromado
- Fácil e rápida instalação e ajuste em altura
- Posicionamento de botão ajustável
- Inclui parafusos de fixação em aço inox para cisterna

- Válvula de descarga simple para cisterna de cerâmica
- Botón de despliegue cromado
- Instalación fácil y rápida y altura ajustable
- Posición de botón ajustable
- Incluye tornillos de acero inoxidable de montaje para cisterna

- Single flush valve for ceramic cistern
- Chromed pull button
- Easy and quick installation with adjustable height
- Adjustable knob position
- Includes cistern stainless steel mounting screws

- Mécanisme de simple débit pour réservoir céramique
- Bouton de tirer chromé
- Installation facile et rapide et hauteur ajustable
- Positionnement du bouton réglable
- Inclut vis de fixations en acier pour réservoir

REF.				€
BK0410100	pull	5	20	17,00

Top

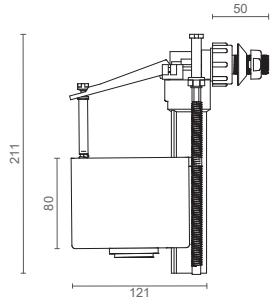

- Torneira boia de entrada de água lateral para autoclismos cerâmicos
- Enchimento rápido e silencioso
- Casquilho em latão

- Grifo flotador de entrada lateral para cisterna de cerâmica
- Llenado rápido y silencioso
- Casquillo de latón

- Side inlet fill valve for ceramic cistern
- Fast and quiet filling
- Brass fitting

- Robinet flotteur d' alimentation latérale pour réservoirs céramiques
- Remplissage rapide et silencieux
- Raccord en laiton

REF.				€
BK0400050	3/8"	10	20	13,40
BK0400060	1/2"	5	20	15,80

Basic

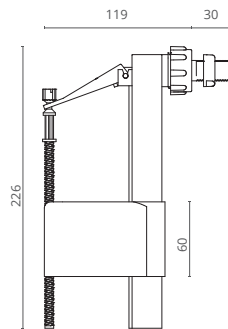

- Torneira boia de entrada de água lateral universal
- Enchimento rápido
- Casquilho em plástico

- Grifo flotador de entrada de agua lateral universal
- Llenado rápido
- Casquillo de plástico

- Universal side water inlet float tap
- Fast filling
- Plastic fitting

- Robinet flotteur universel à entrée d'eau latérale
- Remplissage rapide
- Douille en plastique

REF.				€
BK0400671	3/8"	10	20	7,10

Simplex

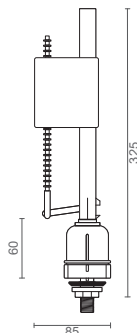

- Torneira boia de entrada de água inferior para autoclismos cerâmicos
- Enchimento rápido e silencioso
- Casquilho em latão

- Grifo flotador de entrada inferior para cisterna de cerâmica
- Llenado rápido y silencioso
- Casquillo de latón

- Bottom inlet fill valve for ceramic cistern
- Fast and quiet filling
- Brass fittings

- Robinet flotteur d' alimentation à la bas pour réservoirs céramiques
- Remplissage rapide et silencieux
- Raccord en laiton

REF.				€
BK0400500	3/8"	10	20	13,00
BK0400540	1/2"	5	20	14,60

Estruturas de instalação · Accesorios para cisternas

Cisterns accessoires · Accessoires pour réservoirs



Tubo descarga
Tubo de descarga
Flush pipe
Tuyau de décharge coudé

REF.	(mm)			€
BK1000000	Ø50 x Ø32 x 325	1	20	5,60
BK1000010	Ø50 x Ø32 x 600	1	30	10,00
BK1000020	Ø50 x Ø32 x 1000	1	25	17,50
BK1000030	Ø50 x Ø40 x 350	1	20	5,60

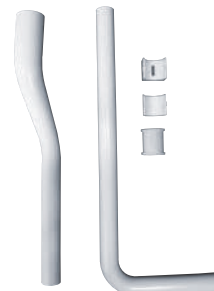

Tubo descarga ajustável
Tubo de descarga ajustable
Tadjustable flush pipe
Tuyau de décharge coudé ajustable

REF.	(mm)			€
BK1000150	Ø50 x Ø32 x 980	1	20	28,30



Tubo descarga p/ autoclismo alto
Tubo de descarga para cisternas altas
Flush pipe for high installation cisterns
Tuyau de décharge pour haute position

REF.	(mm)			€
BK1000100	Ø32	1	20	18,50



Porca p/ tubo descarga
Tuerca del tubo de descarga
Nut for flush pipe
Écrou tuyau de décharge

REF.				€
BK1050010	5 un	1	20	14,90



Anilha p/ tubo descarga
O-ring para tubo de descarga
O-ring for flush pipe
Bague tuyau de décharge

REF.				€
BK1050020	10 un	1	20	5,60



Vedante cónico p/ tubo descarga
Junta cónica para tubo de descarga
Conical seal for flush pipe
Joint conique tuyau de décharge

REF.				€
BK1050000	10 un	1	20	8,70

Estruturas de instalação · Accesorios para cisternas

Cisterns accessoires · Accessoires pour réservoirs



Vedante válvula descarga
Junta del descargador
Seal flush valve
Joint mecanisme de chasse

REF.				€
BK1002000	10 un	1	20	18,80

Para autoclismos Ctesi
Para cisternas Ctesi
For Ctesi cisterns
Pour réservoirs Ctesi



Vedante válvula / cisterna
Junta descargador/cisterna
Seal valve/cistern
Joint mecanisme/réservoir

REF.	(mm)			€
BK1002100	85 x 57 x 8 - 5 un	-	50	5,10

compatível com todas as louças sanitárias
compatible con todos los productos sanitarios
compatible with all sanitary items
compatible avec tous les produits sanitaires



Junta de vedação - cisterna / sanita
Junta cisterna / inodoro
Sealing gasket cistern/toilet
Joint réservoir/cuvette

REF.	(mm)			€
BK1002110	110 x 70 x 20 - 5 un	-	30	8,50

compatível com todas as louças sanitárias
compatible con todos los productos sanitarios
compatible with all sanitary items
compatible avec tous les produits sanitaires



Porca plástica p/ casquillo
Tuerca para casquillo - lateral
Nut for fitting - side
Écrou plastique p/ raccord - latéral

REF.				€
BK1050100	lateral 3/8" - 10 un	-	10	5,00
BK1050110	lateral 1/2" - 10 un	-	10	5,30



Porca plástica p/ casquillo
Tuerca para casquillo - inferior
Nut for fitting - bottom
Écrou plastique p/ raccord - à la bas

REF.				€
BK1050120	inferior 3/8" - 10 un	-	10	5,00
BK1050130	inferior 1/2" - 10 un	-	10	5,30



Tampão plástico lateral
Tapa lateral
Side plastic disk
Couvercle plastique latérale

REF.				€
BK1050200	3/8" - 10 un	-	10	3,35
BK1050210	1/2" - 10 un	-	10	3,95



Tampão plástico inferior
Tapa inferior
Bottom plastic disk
Couvercle plastique bas

REF.				€
BK1050220	3/8" - 5 un	-	10	15,70
BK1050230	1/2" - 5 un	-	10	16,70



Vedante inferior torneira boia
Junta para grifo flotador
Seal inlet valve
Joint robinet flotteur

REF.				€
BK1002200	3/8" - 10 un	-	10	6,20
BK1002210	1/2" - 10 un	-	10	6,90



Borrachas p/ kit parafusos cisterna
Goma para tornillos de cisterna
Rubber for cistern screws
Caoutchouc pour vis cistern

REF.				€
BK1050320	10 un	-	10	7,30

compatível com todas as louças sanitárias
compatible con todos los productos sanitarios
compatible with all sanitary items
compatible avec tous les produits sanitaires



Kit 2 parafusos fixação cisterna
Set de fijación de la cisterna
Cistern fixing screws kit
Kit de vis de fixation réservoir

REF.				€
BK1050310	M6 x 80 - inox	5	10	5,60

compatível com todas as louças sanitárias
compatible con todos los productos sanitarios
compatible with all sanitary items
compatible avec tous les produits sanitaires



Emboque sanita interior
Junta interna de goma
Internal clamp gasket
Joint cuvette interieur

REF.				€
BK2006000	Ø32/40 - 10 un	-	25	10,60



Emboque sanita interior
Junta interna de goma
Internal clamp gasket
Joint cuvette interieur

REF.				€
BK2006020	Ø32 - 10 un	-	10	10,30
BK2006021	Ø40 - 10 un	-	10	10,30

Tubos extensíveis · Manguitos flexíveis

Flexible tubes · Tubes extensibles

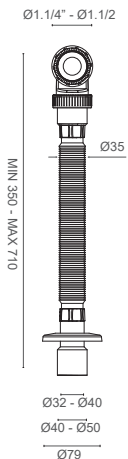

Tubo extensível com curva
Manguito flexible con codo
Flexible hose with bend
Tuyau flexible courbé

REF.				€
BK2000220	1.1/4" x 32/40	10	80	4,40



poupança de espaço
ahorro de espacio
space saving
gain de place



inclui adaptador
1.1/4 → 1.1/2

Kit extensível c/ vedante plano
Kit flexible c/ junta plana
Kit flexible w/ flat seal
Kit flexivle a/ joint plat

REF.				€
BK2001200	1.1/4" x 32/40	10	80	2,40



inclui adaptador
1.1/2 → 1.3/4

Kit extensível c/ vedante plano
Kit flexible c/ junta plana
Kit flexible w/ flat seal
Kit flexivle a/ joint plat

REF.				€
BK2001220	1.1/2" x 40/50	10	80	2,50

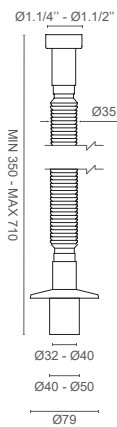

Kit extensível c/ vedante plano
Kit flexible c/ junta plana
Kit flexible w/ flat seal
Kit flexivle a/ joint plat

REF.				€
BK2001000	1.1/4" x 32/40	10	80	3,00
BK2001020	1.1/2" x 40/50	10	80	3,20

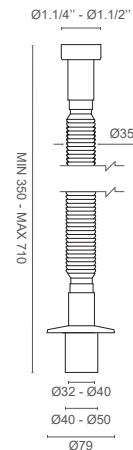

Kit extensível c/ vedante cônico
Kit flexible c/ junta conica
Kit flexible w/ conical seal
Kit flexivle a/ conique plat

REF.				€
BK2001100	1.1/4" x 32/40	10	80	3,20
BK2001120	1.1/2" x 40/50	10	80	3,40

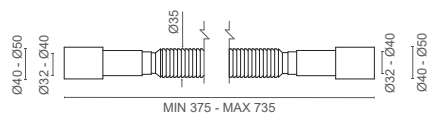

Simples
Simples
Simple
Simple

REF.				€
BK2000000	32/40 x 32/40	10	100	1,90
BK2000020	40/50 x 40/50	10	100	1,95

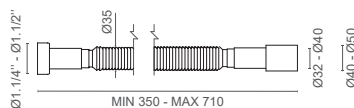

Vedante plano c/ porca
Junta plana con tuerca
Flat seal with nut
Joint plat avec écrou

REF.				€
BK2000100	1.1/4" x 32/40	10	100	1,90
BK2000120	1.1/2" x 32/40	10	100	2,00
BK2000121	1.1/2" x 40/50	10	100	2,00

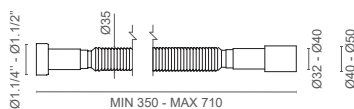

Vedante cónico c/ porca
Junat conica con tuerca
Conical seal with nut
Joint conique avec écrou

REF.				€
BK2000400	1.1/4" x 32/40	10	100	2,10
BK2000421	1.1/2" x 40/50	10	100	2,30

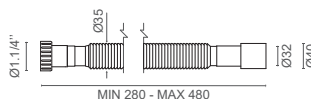

Vedante plano c/ porca - bidé
Junta plana con tuerca - bidé
Flat seal with nut - bidet
Joint plat avec écrou - bidet

REF.				€
BK2000200	1.1/4" x 32/40	10	100	2,95

Tubos extensíveis com válvula · Manguitos flexibles con válvula
 Flexible tubes with valve · Tubes flexibles avec valve

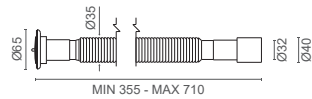

REF.				€
BK2000500	1.1/4" x 32/40	10	80	5,30

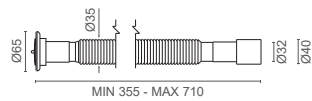

Válvula roscada 1.1/4"
 Válvula roscada
 Threaded valve
 Vidage Fileté

REF.				€
BK2000550	1.1/4" x 32/40	10	80	5,90

Tubos extensíveis cromados · Manguitos flexibles cromados
 Chromed extensibles tubes · Tubes extensibles avec valve

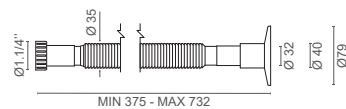

Com vedante plano
 Con junta plana
 With flat seal
 Avec joint plat

REF.				€
BK2000600	1.1/4" x 32/40	10	100	6,80

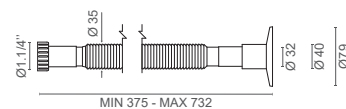

Com vedante cónico
 Con junta conica
 With conical seal
 Avec joint conique

REF.				€
BK2000700	1.1/4" x 32/40	10	100	7,10

Acessórios · Acesoios
Accessories · Accessoires

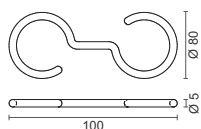

Gancho cromado
 Gancho doble
 Double hook
 Crochet double

REF.				€
BK2050110	cromado - 10 un cromo	-	20	10,10

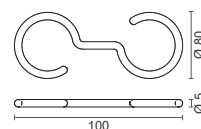

Gancho branco
 Gancho doble
 Double hook
 Crochet double

REF.				€
BK2050100	branco - 10 un blanco	-	20	4,20

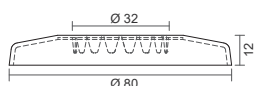

Espelho cromado
 Plafón embellecedor - cromado
 Wall flange - chromed
 Rosace - chromé

REF.				€
BK2050210	Ø32 / 40 - 10 un	-	20	13,50

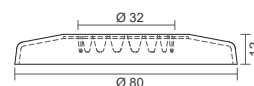

Espelho branco
 Plafón embellecedor - blanco
 Wall flange - white
 Rosace - blanc

REF.				€
BK2050200	Ø32 / 40 - 10	-	20	6,20

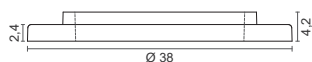

Vedante plano
 Junta plana
 Flat seal
 Joint plat

REF.				€
BK2050000	1.1/4" - 10 un	-	50	5,60
BK2050010	1.1/2" - 10 un	-	50	5,60

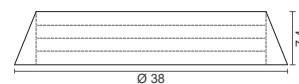

Vedante cónico
 Junta cónica
 Conical seal
 Joint conique

REF.				€
BK2050020	1.1/4" - 10 un	-	50	5,60
BK2050030	1.1/2" - 10 un	-	50	5,60

Excêntricos e canhões de sanita · Manguitos excêntricos

Toilet eccentric · Raccord excentré

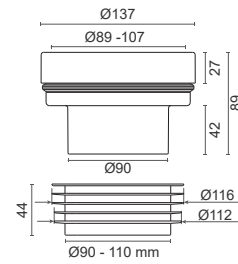

Flexy canhão sanita direito
Flexy manguito wc recto
Flexy wc straight connector
Flexy raccord droit wc

REF.				€
BK2002200	Ø 90 / 100 / 110 mm	10	40	5,40

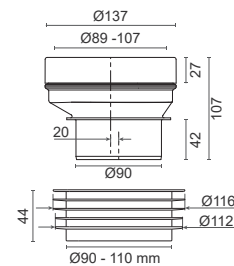

Flexy excêntrico sanita 20 mm
Flexy manguito wc 20mm
Flexy wc 20mm connector
Flexy raccord wc 20mm

REF.				€
BK2002210	Ø 90 / 100 / 110 mm	20	40	5,40

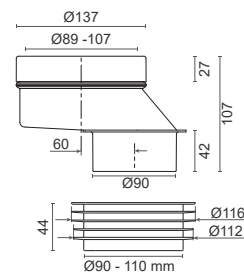

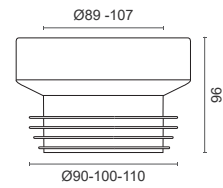

Flexy excêntrico sanita 40 mm
Flexy manguito wc 40 mm
Flexy wc connector 40 mm
Flexy raccord wc 40 mm

REF.				€
BK2002220	Ø 90 / 100 / 110 mm - 40 mm	10	20	5,80



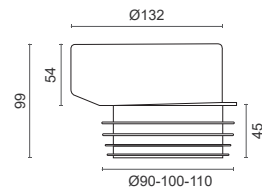

Fita canhão sanita direito
Manguito elástico recto
Straight connector
Raccord droit

REF.				€
BK2002000	Ø 90 / 100 / 110 mm	10	75	2,20



Fita excêntrico sanita 40 mm
Manguito elástico excêntrico 40 mm
Eccentric for toilet 40 mm
Raccord excentré de toilette 40 mm

REF.				€
BK2002100	Ø 90 / 100 / 110 mm	10	75	2,30

Curvas de sanita · Codos inodoro Toilet connectors wc · Connecteurs cuvette

Tubo facilmente recortável
Tubo fácilmente recortable
Easy cuttable pipe
Tube facilement coupable

Especialmente indicada para fácil ligação ao chão em sanitas de descarga à parede.

Particularly suitable for easy ground connection in flush toilets.



Especialmente indicada para fácil conexión al suelo en inodoros de descarga a la pared.

Particulièrement indiqué pour une connexion facile au sol dans les toilettes au ras du mur.

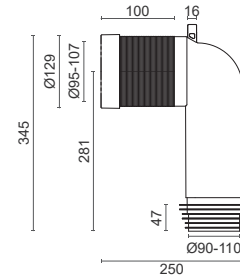

Curva sanita c90
Codo inodoro c90
Toilet connector c90
Connecteur cuvette c90

REF.		2	12	€
BK2002820	Ø90/100/110 mm			20,20

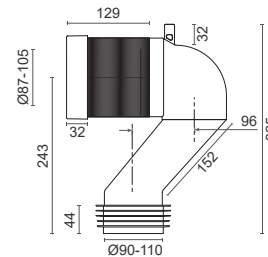

Curva sanita c45
Codo inodoro c45
Toilet connector c45
Connecteur cuvette c45

REF.		2	12	€
BK2002810	Ø90/100/110 mm			18,60

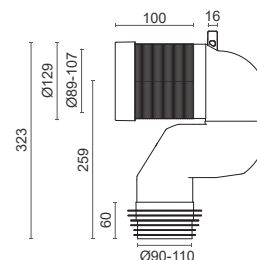

Curva sanita s90
Codo inodoro s90
Toilet connector s90
Connecteur cuvette s90

REF.		2	12	€
BK2002800	Ø90/100/110 mm			19,10

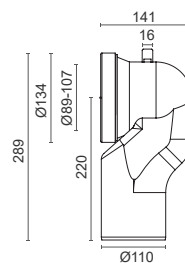

Curva sanita L
Codo inodoro L
Toilet connector L
Connecteur cuvette L

REF.				€
BK2002840	Ø100/110 mm	2	12	12,40

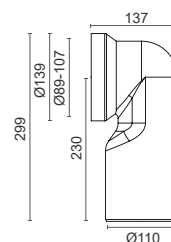

Curva sanita C
Codo inodoro C
Toilet connector C
Connecteur cuvette C

REF.				€
BK2002830	Ø100/110 mm	2	12	13,00

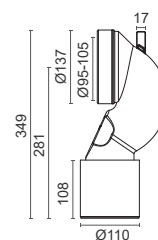

Curva sanita S
Codo inodoro S
Toilet connector S
Connecteur cuvette S

REF.				€
BK2002850	Ø100/110 mm	2	12	17,00

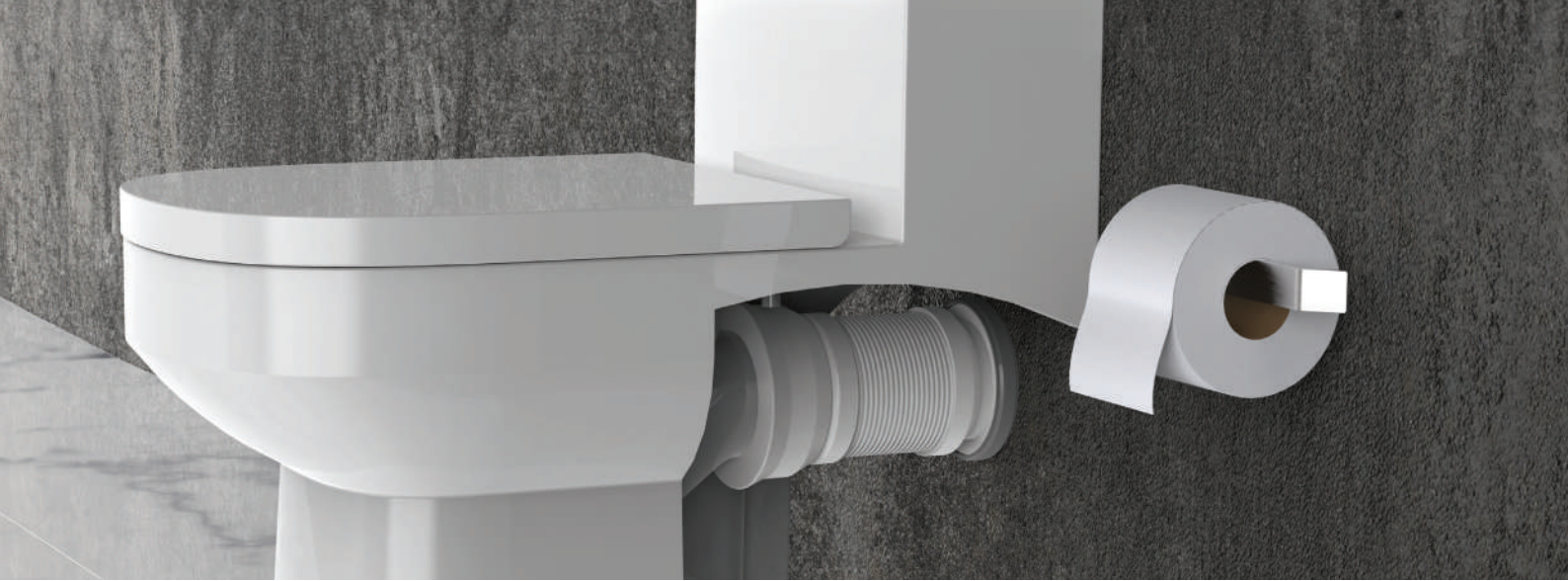

Tubos de sanita · Manguitos inodoro Toilet tube wc · Tuyaux de toilettes

Ideal para renovação dada a facilidade de aplicação sem necessidade de retirar a sanita. Adapta-se a todas as configurações, mesmo as mais complexas.

Ideal for renewal given the ease of application without need to remove the toilet. Adapts to all, even the most complex configurations.

Ideal para la renovación dada la facilidad de aplicación sin necesidad de retirar el inodoro. Se adapta a todo, incluso las configuraciones más complejas.

Idéal pour rénovation vu la facilité d'application sans avoir besoin d'enlever les toilettes. Adaptable à tous, même les configurations les plus complexes.

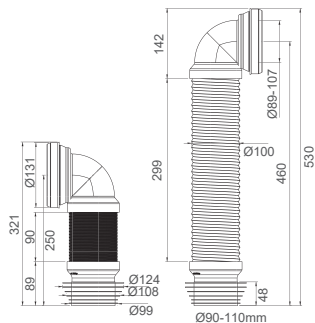

REF.

BK2002510

ø90/110 x 320/530 mm



€

5

24

9,60

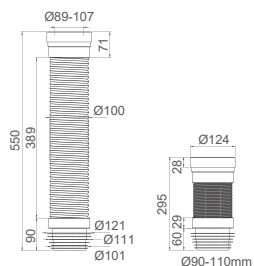

REF.

BK2002500

ø90/110 x 300/550 mm



€

5

30

8,00

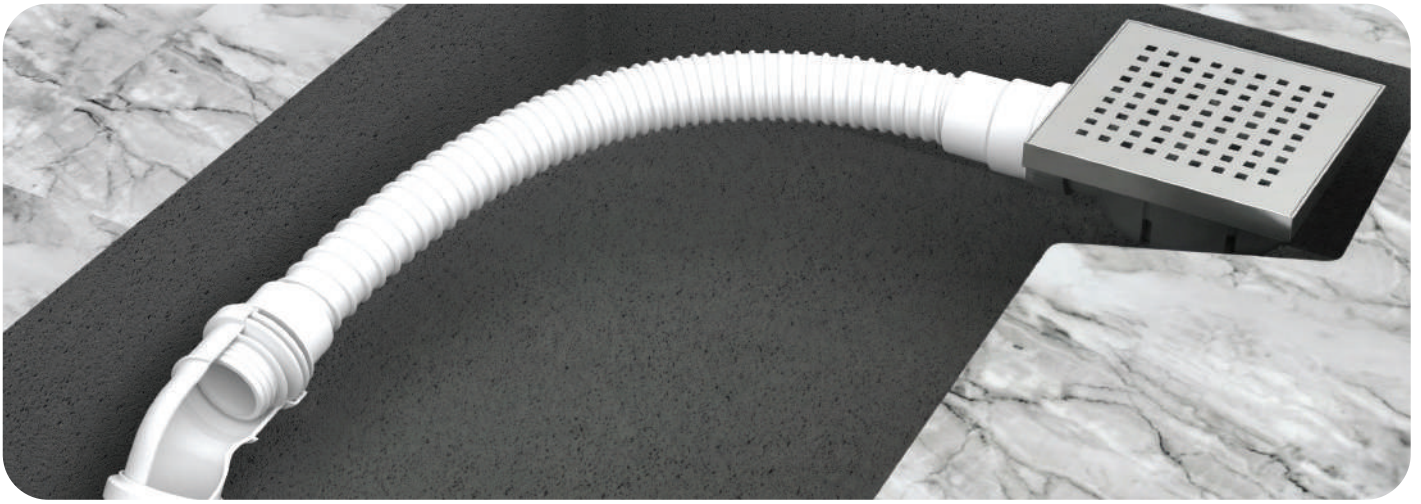

Tubos flexíveis · Manguitos flexibles
 Flexible tubes · Tubes flexibles

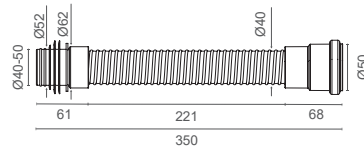

REF.				€
BK2002700	ø50 / ø40-50 x 350 mm	5	60	6,90

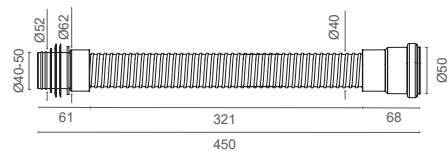

REF.				€
BK2002710	ø50 / ø40-50 x 450 mm	5	50	8,10

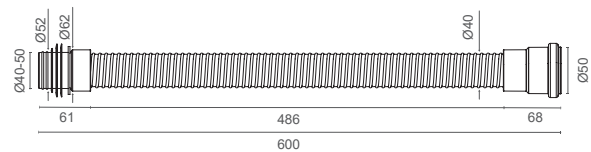

REF.				€
BK2002720	ø50 / ø40-50 x 600 mm	5	40	9,40



Calhas de duche · Canaletas de ducha Shower drains · Caniveaux de douche

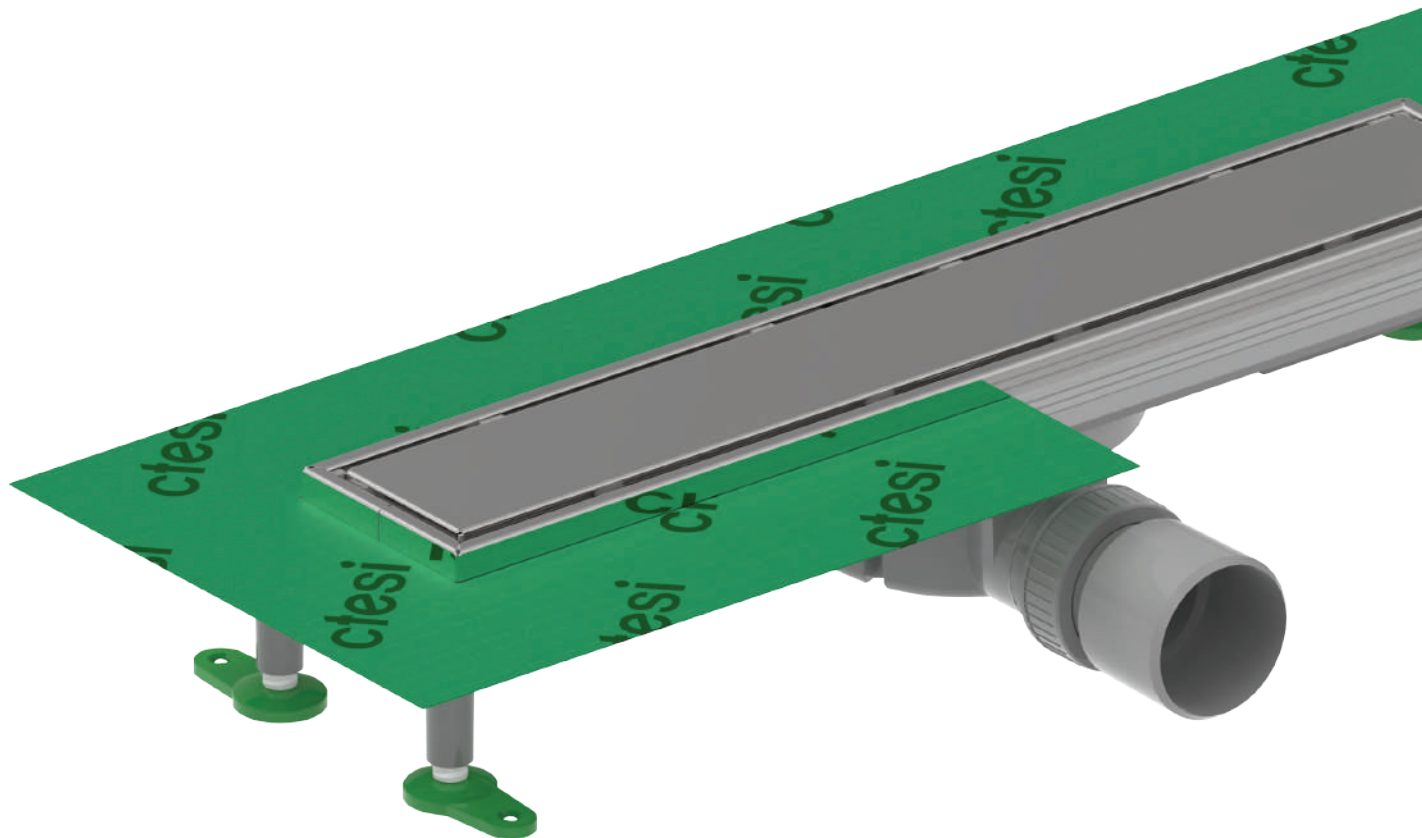

ESTÉTICA E EFICÁCIA

As calhas de duche Ctesi garantem uma drenagem rápida e eficaz enquanto conferem ao seu espaço de banho uma beleza ímpar, ocultando o sifão e possibilitando que o espaço de duche seja pavimentado com o material da sua eleição.

- Corpo em polipropileno reforçado
- Fornecido com tela impermeabilizante ISOL, para melhor isolamento
- Inclui niveladores para melhor adaptabilidade
- Para aplicação em espaços de duche
- Disponível nos comprimentos de 330, 400, 500, 600, 700 e 800mm
- Equipadas com sistema anti-retorno de odores
- Alta resistência química e a temperaturas entre os -30°C e os +75°C

TOP DESIGN AND EFFECTIVENESS

Ctesi shower drains guarantee a fast and efficient drainage while giving your bathroom space a unique beauty, hiding the siphon and allowing you to pave your shower space with whichever material you choose.

- With isolation membrane for better sealing
- Includes levers for better adaptability
- To be used in shower areas
- Available in lengths of: 330, 400, 500, 600, 700, 800mm
- Equipped with anti-odor system
- High chemical resistance and to temperatures between -30°C +75°C

ESTÉTICA Y EFICIENCIA

Las canaletas de ducha Ctesi garantizan un desagüe rápido y eficaz mientras confieren una belleza única a tu espacio de baño, ocultando el sifón y permitiendo pavimentar el espacio de ducha con el material que prefieres.

- Canaleta de ducha con cuerpo de polipropileno
- Con membrana impermeabilizante para un mejor sellado
- Incluye niveladores para una mejor adaptabilidad
- Para uso en áreas de ducha
- Disponible en longitudes de: 330, 400, 500, 600, 700, 800mm
- Equipado con sistema antiolor
- Alta resistencia química y a temperaturas entre -30°C +75°C

ESTHÉTIQUE ET EFFICACITÉ

Les caniveaux de douche Ctesi garantissent un drainage rapide et efficace tout en donnant une beauté unique à votre salle de bains, en cachant le siphon et en permettant à l'espace de douche d'être pavé avec le matériel que vous préférez.

- Caniveau de douche avec corps en polypropylène
- Avec des niveleurs, pour une meilleure adaptabilité
- Avec membrane pour une meilleure imperméabilisation
- Pour une utilisation des zones de douche
- Disponible en longueurs de: 330, 400, 500, 600, 700, 800mm
- Équipé d'un système anti-odeurs
- Haute résistance chimique et à températures entre -30°C +75°C



Dual

A nova calha de duche CTESI – DUAL – é uma inovação que combina design e engenharia. Garantindo um escoamento ultra eficiente da água do duche, o seu inovador sistema de escoamento duplo (um visível e outro oculto), previne potenciais danos causados por águas infiltradas.

La nueva canaleta de ducha CTESI - DUAL - es una innovación que combina diseño e ingeniería. Garantizando un drenaje ultra eficiente del agua de la ducha, su innovador sistema de drenaje doble (uno visible y otro oculto) evita preocupaciones al prevenir posibles daños causados por aguas infiltradas.

The new CTESI - DUAL - shower drain is an innovation that combines design and engineering. Ensuring ultra-efficient drainage of shower water, its innovative dual drainage system (one visible and one hidden) avoids concerns by preventing potential damage caused by water infiltration.

Le nouveau caniveau de douche CTESI - DUAL - est une innovation qui allie design et ingénierie. Garantissant un drainage ultra efficace de l'eau de la douche, son système de drainage innovant à double flux (un visible et un caché) évite les préoccupations en prévenant les éventuels dommages causés par les infiltrations d'eau.

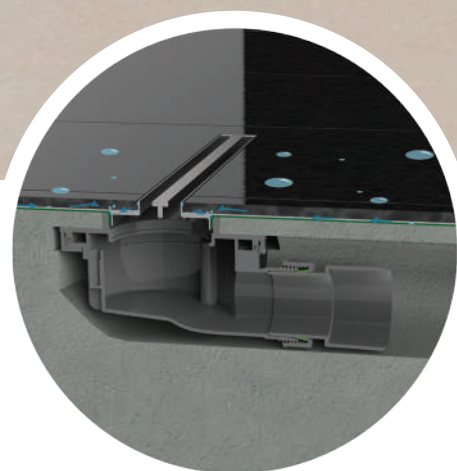

DUAL

mm	escovado · cepillado · brushed · brossé							brilho · brillo · shine · briler				1	10
	inox acero stainless steel acier inox	€	preto negro black noir	€	ouro oro gold or	bronce bronce bronze bronze	grafite grafito graphite graphite	€	ouro oro gold or	bronce bronce bronze bronze	310,00		
600	BK4024930	180,00	BK4024931	230,00	BK4024932	BK4024933	BK4024934	280,00	BK4024935	BK4024936	310,00	1	10
800	BK4024950	205,00	BK4024951	255,00	BK4024952	BK4024953	BK4024954	305,00	BK4024955	BK4024956	340,00	1	10



INOX
ACERO
STAINLESS STEEL
ACIER INOX

PRETO ESCOVADO
NEGRO CEPILLADO
BRUSHED BLACK
NOIR BROSSÉ

OURO BRILHO
ORO BRILLO
SHINE GOLD
OR BRILLER

OURO ESCOVADO
ORO CEPILLADO
BRUSHED GOLD
OR BROSSÉ

BRONZE BRILHO
BRONCE BRILLO
SHINE BRONZE
BRONZE BRILLER

BRONZE ESCOVADO
BRONCE CEPILLADO
BRUSHED BRONZE
BRONZE BROSSÉ

GRAFITE ESCOVADO
GRAFITO CEPILLADO
BRUSHED GRAPHITE
GRAPHITE BROSSÉ





GRELHAS EM VIDRO TEMPERADO
REJILLAS DE VIDRIO TEMPLADO
TEMPERED GLASS GRID
GRILLE EN VERRE TREMPÉ

As linhas simples e os acabamentos elegantes do vidro, conferem uma sensação única de personalização e leveza. A elevada resistência aos impactos e a facilidade de limpeza, tornam as grelhas de vidro uma opção higiênica e segura no espaço de banho.

The simple lines and elegant finishes of the glass give a unique feeling of personalization and lightness. The high impact resistance and ease of cleaning make the shower to a new level of sophistication. Glass grates are a hygienic and safe option in the bathroom.

Las líneas simples y los elegantes acabados del vidrio dan un sensación única de personalización y ligereza. La alta resistencia al impacto y la facilidad de limpieza hacen que el Las rejillas de cristal son una opción higiênica y segura en el baño.

Les lignes simples et les finitions élégantes du verre donnent un sensation unique de personnalisation et de légèreté. La haute résistance aux chocs et la facilité de nettoyage rendent le Les grilles en verre sont une option hygiênique et sûre dans la salle de bain.

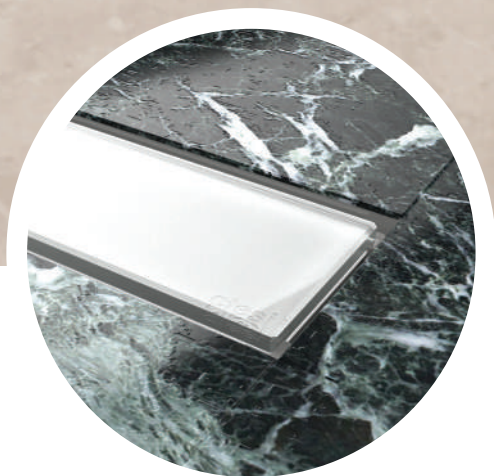

Crystal



CRYSTAL

branco · blanco
white · blanc

preto · nero
black · noir

					€
BK4024310	BK4024410	400 mm	1	10	130,00
BK4024330	BK4024430	600 mm	1	10	150,00
BK4024350	BK4024450	800 mm	1	10	170,00

Nizak

12mm

O modelo Nizak é a evolução com uma profundidade de grelha de 12mm, que permite ajustar a altura da espessura do pavimento cerâmico.

Esta é uma mudança que proporciona maior liberdade na escolha dos revestimentos, agregando personalidade e sofisticação ao espaço do duche.

The Nizak model is the evolution with a grid depth of 12mm, which allows you to adjust the thickness height of the ceramic floor.

This is a change that provides greater freedom in choosing coverings, adding personality and sophistication to the shower space.

El modelo Nizak es la evolución con un fondo de rejilla de 12mm, que permite ajustar la altura del espesor del piso cerámico.

Se trata de un cambio que aporta mayor libertad a la hora de elegir los revestimientos, aportando personalidad y sofisticación al espacio de ducha.

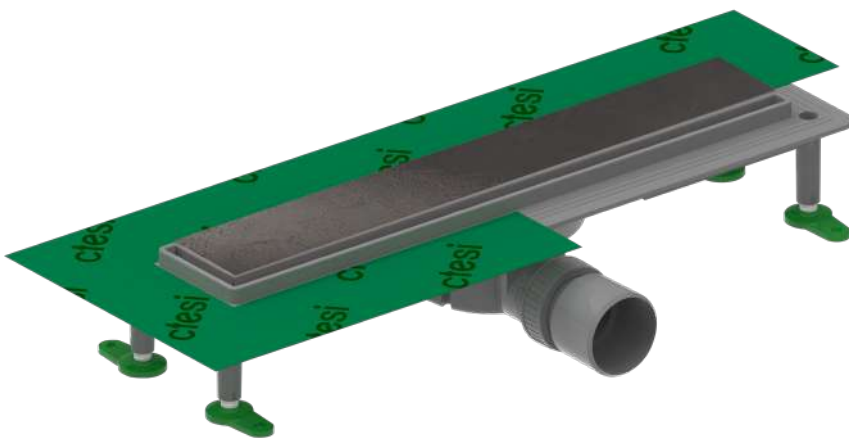

Le modèle Nizak est l'évolution avec une profondeur de grille de 12mm, qui permet d'ajuster la hauteur de l'épaisseur du plancher de céramique.

Il s'agit d'un changement qui offre une plus grande liberté dans le choix des revêtements, en ajoutant de la personnalité et du raffinement à l'espace douche.



*As medidas 330, 500 e 700 estão disponíveis sob encomenda
Los tamaños 330, 500 y 700 están disponibles bajo pedido
Sizes 330, 500 and 700 are available upon request
Les tailles 330, 500 et 700 sont disponibles sur demande

NIZAK

cm		€		€		
400	BK4024810	90,00	BK4024811	105,00	1	10
600	BK4024830	110,00	BK4024831	130,00	1	10
800	BK4024850	125,00	BK4024851	145,00	1	10



PARA PAVIMENTOS ATÉ 12 mm
Para suelos hasta 12mm
For embedding tiles until 12mm
Pour céramique jusqu'à 12mm

Way & Flow



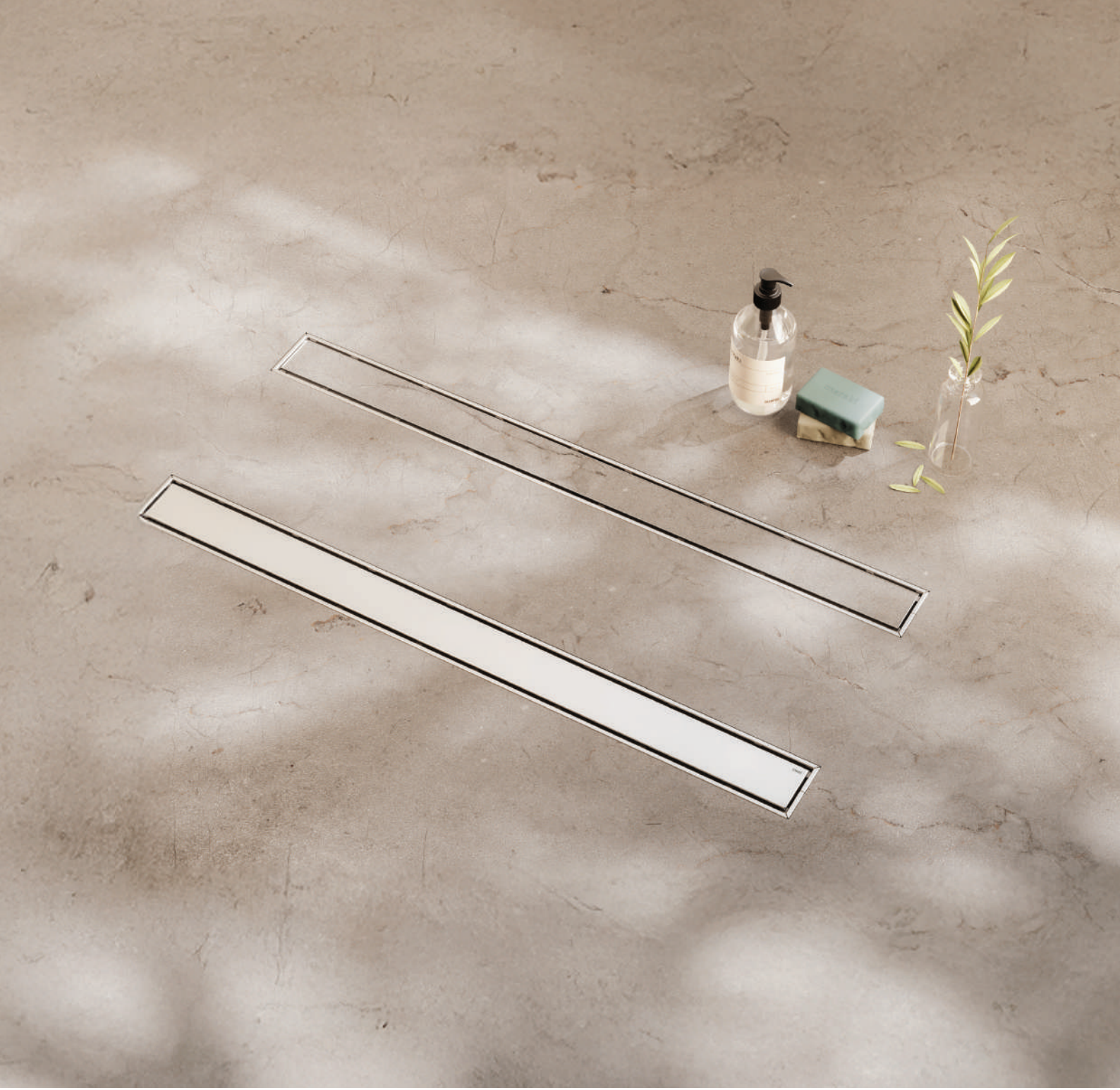

line



square

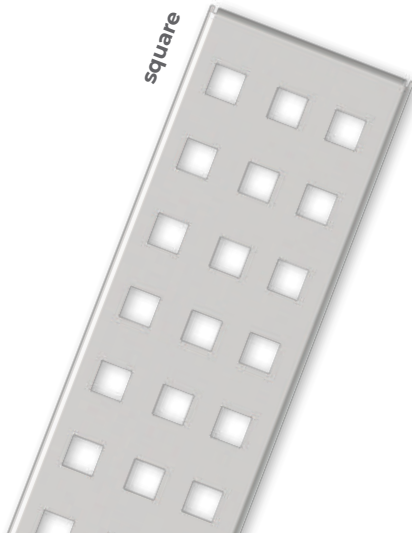

round

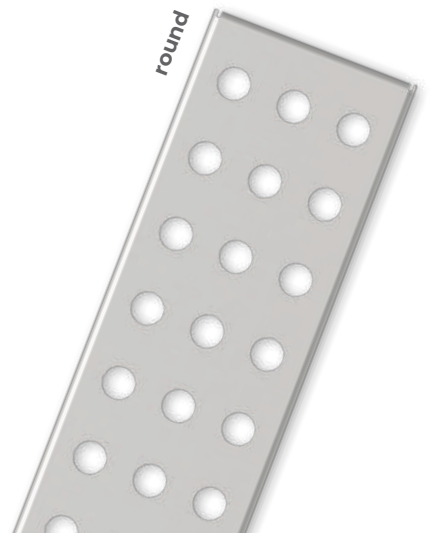

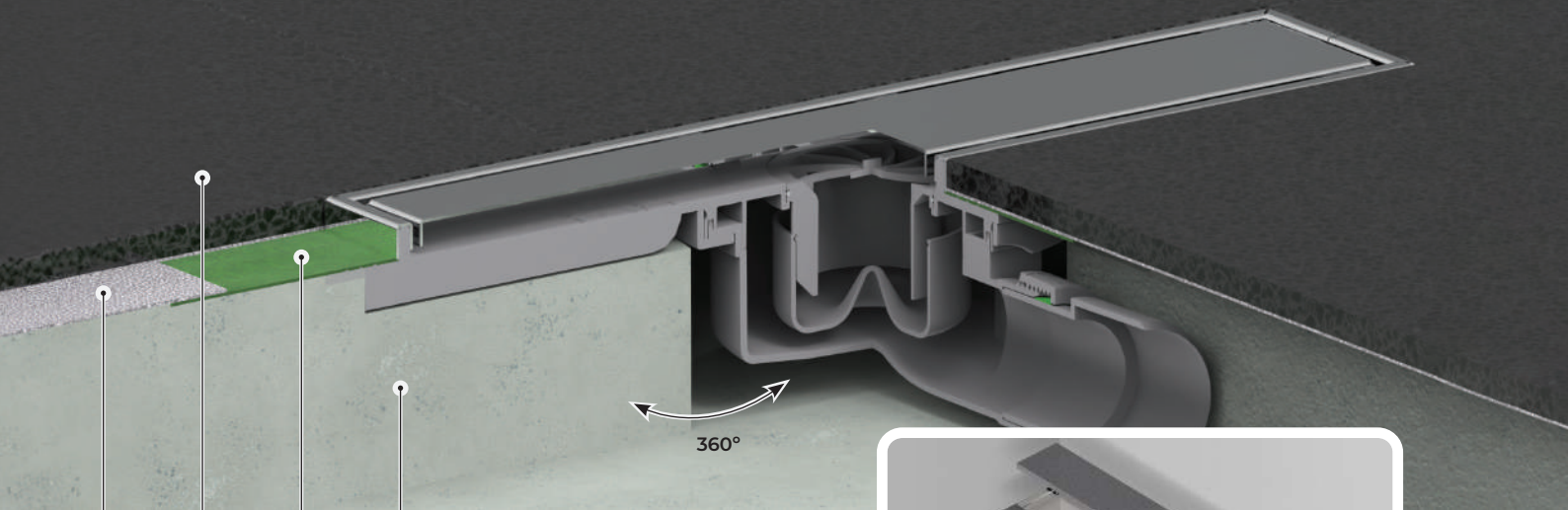

BETÃO
HORMIGÓN
CONCRETE
BÉTON

ISOL - TELA IMPERMEABILIZANTE
LAMINA IMPERMEABILIZANTE
WATERPROOFING MEMBRANE
D'IMPERMEABILISATION

PAVIMENTO DE CERÂMICA
SUPERFICIE DE CERAMICA
CERAMIC SURFACE
SURFACE CERAMIQUE

MATERIAL DE ISOLAMENTO
MATERIAL DE AISLAMIENTO
INSULATION MATERIAL
MATERIEL D'ISOLATION



Personalize a grelha da calha com a mesma cerâmica utilizada no pavimento, para isso basta inverter a face da grelha e aplicar a cerâmica, que deve ter uma espessura de 6 mm.

Personaliza la rejilla de la canaleta con la misma cerámica que utilizas en el suelo. Para ello basta con invertir la rejilla y aplicarla en la cerámica.

Customize the grill with the ceramic you have used on the floor. In order to do this you must invert the grill and apply it on the ceramic.

Personnalisez la grille avec la même céramique que vous utilisez sur le sol. Pour ce faire, inversez simplement la grille et appliquez-la sur la céramique.

Way Line

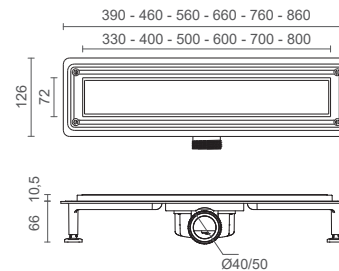
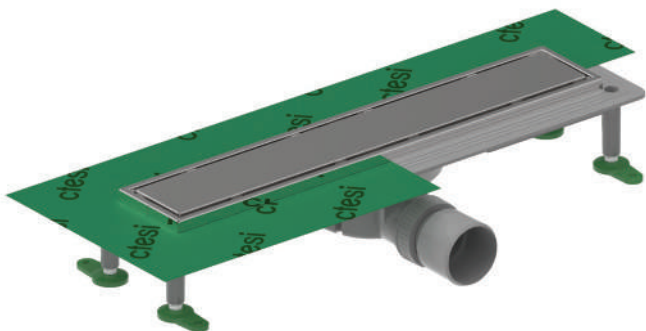

- Grelha e Aro em aço inox AISI 304
- Largura de 60 mm

- Rejilla y marco en acero inoxidable AISI 304
- 60 mm de ancho

- AISI 304 Stainless steel grill and frame
- 60 mm width

- Grille et cadre en acier inoxydable AISI 304
- 60 mm de largeur

mm		€		€		
330	BK4024002	90,00	BK4024003	110,00	1	10
400	BK4024012	100,00	BK4024013	120,00	1	10
500	BK4024022	110,00	BK4024023	130,00	1	10
600	BK4024032	117,50	BK4024033	137,50	1	10
700	BK4024042	125,00	BK4024043	145,00	1	10
800	BK4024052	130,00	BK4024053	150,00	1	10

Way Square

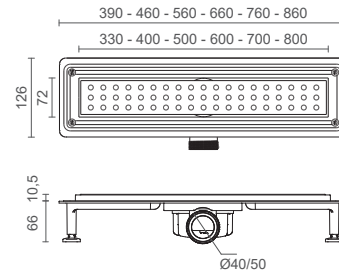
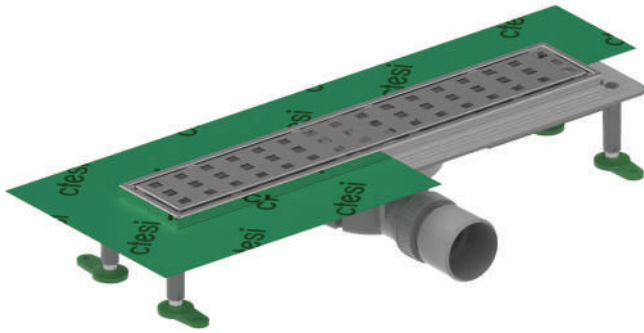

- Grelha e Aro em aço inox AISI 304
- Largura de 60 mm
- Rejilla y marco en acero inoxidable AISI 304
- 60 mm de ancho
- AISI 304 Stainless steel grill and frame
- 60 mm width
- Grille et cadre en acier inoxydable AISI 304
- 60 mm de largeur

mm		€		€		
330	BK4024102	90,00	BK4024103	110,00	1	10
400	BK4024112	100,00	BK4024113	120,00	1	10
500	BK4024122	110,00	BK4024123	130,00	1	10
600	BK4024132	117,50	BK4024133	137,50	1	10
700	BK4024142	125,00	BK4024143	145,00	1	10
800	BK4024152	130,00	BK4024153	150,00	1	10

Way Round

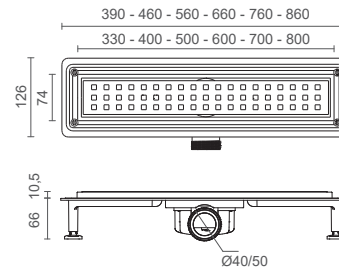
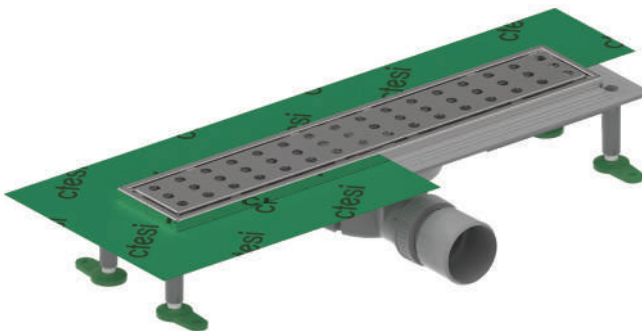

- Grelha e Aro em aço inox AISI 304
- Largura de 60 mm
- Rejilla y marco en acero inoxidable AISI 304
- 60 mm de ancho
- AISI 304 Stainless steel grill and frame
- 60 mm width
- Grille et cadre en acier inoxydable AISI 304
- 60 mm de largeur

mm		€		€		
330	BK4024202	90,00	BK4024203	110,00	1	10
400	BK4024212	100,00	BK4024213	120,00	1	10
500	BK4024222	110,00	BK4024223	130,00	1	10
600	BK4024232	117,50	BK4024233	137,50	1	10
700	BK4024242	125,00	BK4024243	145,00	1	10
800	BK4024252	130,00	BK4024253	150,00	1	10

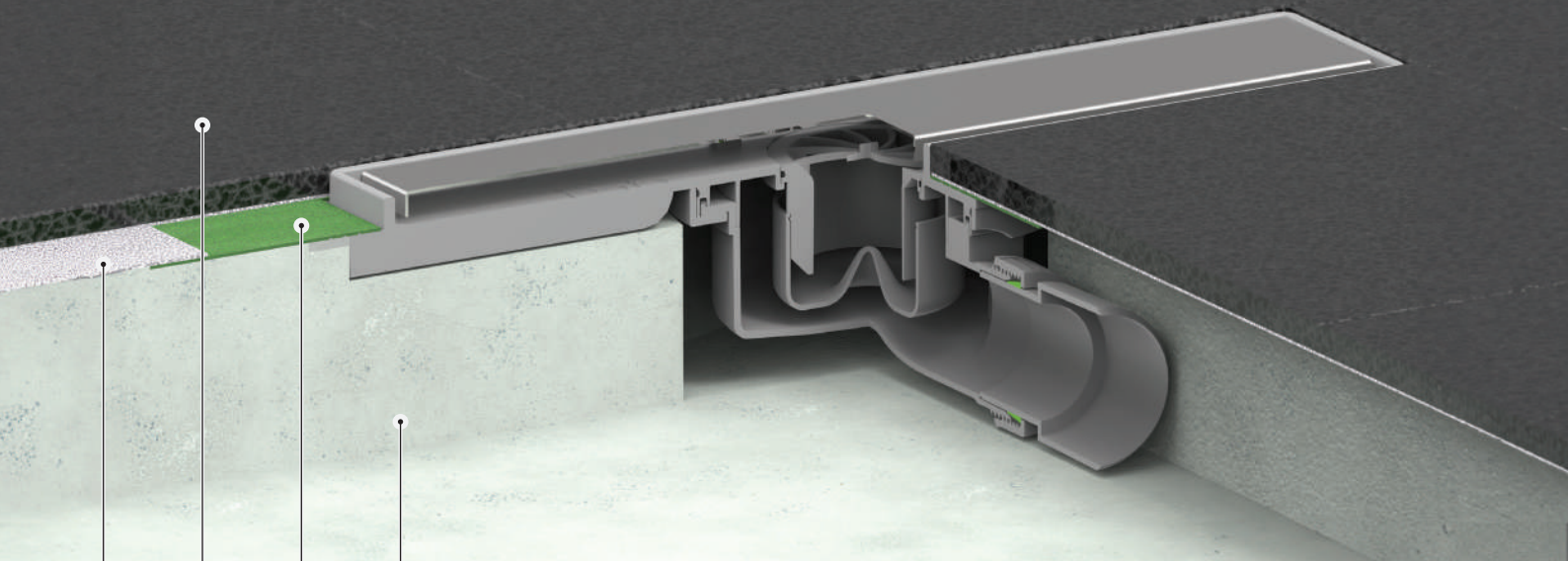

BETÃO · HORMIGÓN
CONCRETE · BÉTON

ISOL · TELA IMPERMEABILIZANTE · LAMINA IMPERMEABILIZANTE
WATERPROOFING MEMBRANE · D'IMPERMEABILISATION

PAVIMENTO DE CERÂMICA · SUPERFICIE DE CERAMICA
CERAMIC SURFACE · SURFACE CERAMIQUE

MATERIAL DE ISOLAMENTO · MATERIAL DE AISLAMIENTO
INSULATION MATERIAL · MATERIEL D'ISOLATION

Flow Line

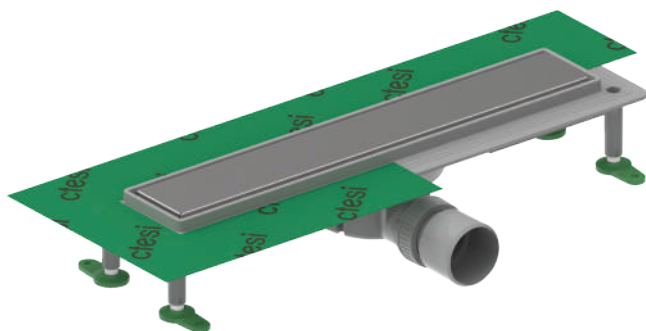
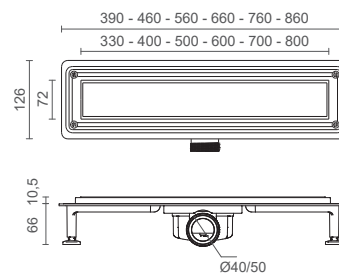





- Grelha em aço inox AISI 304
- Largura de 60 mm

- Rejilla en acero inoxidable AISI 304
- 60 mm de ancho

- AISI 304 Stainless steel grill
- 60 mm width



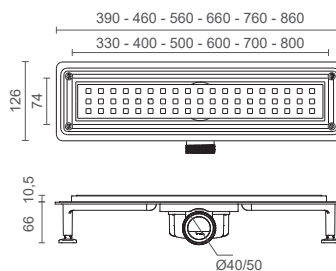
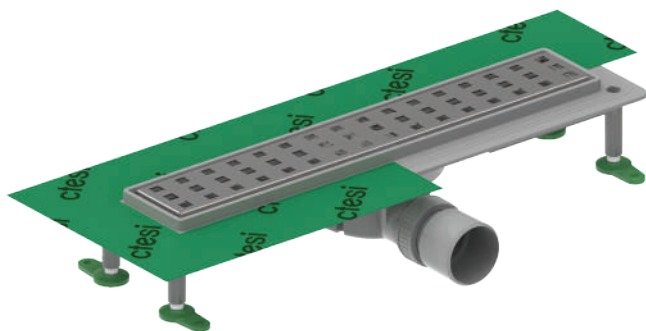

- Grille en acier inoxydable AISI 304
- 60 mm de largeur

mm		€		€		
330	BK4024501	70,00	BK4024502	85,00	1	10
400	BK4024511	75,00	BK4024512	90,00	1	10
500	BK4024521	85,00	BK4024522	100,00	1	10
600	BK4024531	90,00	BK4024532	110,00	1	10
700	BK4024541	95,00	BK4024542	115,00	1	10
800	BK4024551	100,00	BK4024552	120,00	1	10

Flow Square





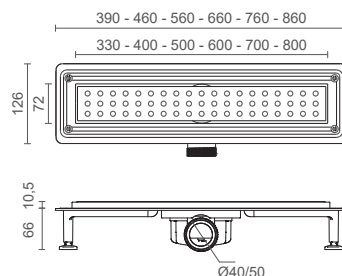
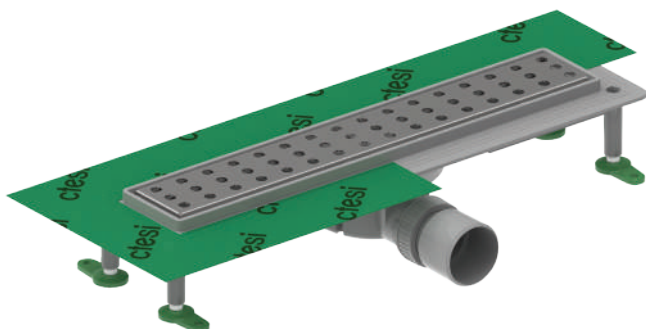

- Grelha em aço inox AISI 304
- Largura de 60 mm
- Rejilla en acero inoxidable AISI 304
- 60 mm de ancho
- AISI 304 Stainless grill
- 60 mm width
- Grille en acier inoxydable AISI 304
- 60 mm de largeur

mm		€		€		
330	BK4024601	70,00	BK4024602	85,00	1	10
400	BK4024611	75,00	BK4024612	90,00	1	10
500	BK4024621	85,00	BK4024622	100,00	1	10
600	BK4024631	90,00	BK4024632	110,00	1	10
700	BK4024641	95,00	BK4024642	115,00	1	10
800	BK4024651	100,00	BK4024652	120,00	1	10

Flow Round



- Grelha em aço inox AISI 304
- Largura de 60 mm
- Rejilla en acero inoxidable AISI 304
- 60 mm de ancho
- AISI 304 Stainless grill
- 60 mm width
- Grille en acier inoxydable AISI 304
- 60 mm de largeur

mm		€		€		
330	BK4024701	70,00	BK4024702	85,00	1	10
400	BK4024711	75,00	BK4024712	90,00	1	10
500	BK4024721	85,00	BK4024722	100,00	1	10
600	BK4024731	90,00	BK4024732	110,00	1	10
700	BK4024741	95,00	BK4024742	115,00	1	10
800	BK4024751	100,00	BK4024752	120,00	1	10



Kit calhas de duche · Kit canaleta de ducha Shower drain kit · Kit caniveau de douche

Este kit é composto por uma calha de duche em polipropileno, grelha de aço inox, tela impermeabilizante ISOL com um 1,5 x 2m para garantir o isolamento completo do espaço de banho e ainda uma cola apropriada para aplicação da tela. Defina o seu espaço de banho e garanta o melhor sistema de drenagem com uma impermeabilização efetiva.

Este kit consta de uma canaleta de ducha de polipropileno, uma rejilla de acero inoxidable, una lámina de impermeabilización ISOL de 1,5 x 2 m para asegurar un aislamiento total del espacio del baño y aún un pegamento adecuado para la aplicación de la lámina. Define el espacio de tu baño y asegura el mejor sistema de drenaje con una impermeabilización eficaz.

This kit consists of a polypropylene shower drain, a stainless steel grill, a 1.5 x 2 m ISOL waterproofing membrane to ensure total isolation of the bathroom space and even a suitable glue to apply the membrane. Define your bathroom's space and have the best drainage system with effective waterproofing.

Ce kit se compose d'un caniveau de douche en polypropylène, d'une grille en acier inoxydable, d'une membrane d'imperméabilisation ISOL de 1,5 x 2 m pour assurer une isolation totale de l'espace salle de bain et même d'une colle adaptée à l'application de la membrane. Définissez l'espace de votre salle de bain et assurez le meilleur système de drainage avec une imperméabilisation efficace.

Personalize a grelha da calha com a mesma cerâmica utilizada no pavimento, para isso basta inverter a face da grelha e aplicar a cerâmica, que deve ter uma espessura de 6 mm.

Personaliza la rejilla de la canaleta con la misma cerámica que utilizas en el suelo. Para ello basta con invertir la rejilla y aplicarla en la cerámica.

Customize the grill with the ceramic you have used on the floor. In order to do this you must invert the grill and apply it on the ceramic.

Personnalisez la grille avec la même céramique que vous utilisez sur le sol. Pour ce faire, inversez simplement la grille et appliquez-la sur la céramique.

Kit Way Line

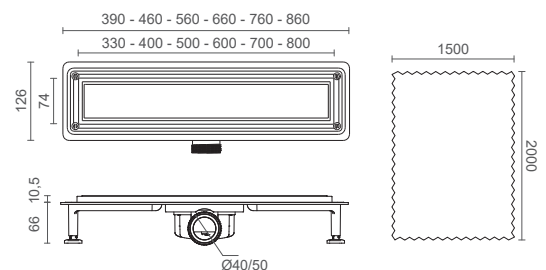





- Grelha e Aro em aço inox AISI 304
- Largura de 60 mm
- Tela Impermeabilizante ISOL com 1,5 x 2m

- Rejilla y marco en acero inoxidable AISI 304
- 60 mm de ancho
- Membrana Impermeabilizante ISOL con 1,5 x 2m

- AISI 304 Stainless steel grill and frame
- 60 mm width
- ISOL Waterproofing membrane with 1,5x2m

- Grille et cadre en acier inoxydable AISI 304
- 60 mm de largeur
- Membrane d'imperméabilisation ISOL avec 1,5x2m

KIT WAY LINE



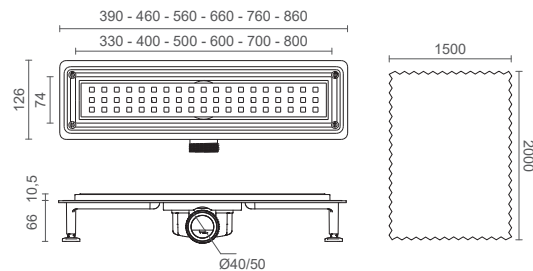

mm		€		€		
330 x 60	BK4023201	130,00	BK4023202	150,00	1	10
400 x 60	BK4023211	135,00	BK4023212	155,00	1	10
500 x 60	BK4023221	140,00	BK4023222	160,00	1	10
600 x 60	BK4023231	145,00	BK4023232	165,00	1	10
700 x 60	BK4023241	155,00	BK4023242	175,00	1	10
800 x 60	BK4023251	165,00	BK4023252	185,00	1	10

Kit Way Square



- Grelha e Aro em aço inox AISI 304
- Largura de 60 mm
- Tela Impermeabilizante ISOL com 1,5 x 2m
- Rejilla y marco en acero inoxidable AISI 304
- 60 mm de ancho
- Membrana Impermeabilizante ISOL con 1,5 x 2m
- AISI 304 Stainless steel grill and frame
- 60 mm width
- ISOL Waterproofing membrane with 1,5x2m
- Grille et cadre en acier inoxydable AISI 304
- 60 mm de largeur
- Membrane d'imperméabilisation ISOL avec 1,5x2m

KIT WAY SQUARE



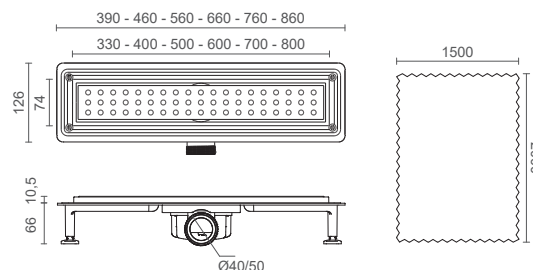

mm		€		€		
330 x 60	BK4023401	130,00	BK4023402	150,00	1	10
400 x 60	BK4023411	135,00	BK4023412	155,00	1	10
500 x 60	BK4023421	140,00	BK4023422	160,00	1	10
600 x 60	BK4023431	145,00	BK4023432	165,00	1	10
700 x 60	BK4023441	155,00	BK4023442	175,00	1	10
800 x 60	BK4023451	165,00	BK4023452	185,00	1	10

Kit Way Round



- Grelha e Aro em aço inox AISI 304
- Largura de 60 mm
- Tela Impermeabilizante ISOL com 1,5 x 2m
- Rejilla y marco en acero inoxidable AISI 304
- 60 mm de ancho
- Membrana Impermeabilizante ISOL con 1,5 x 2m
- AISI 304 Stainless steel grill and frame
- 60 mm width
- ISOL Waterproofing membrane with 1,5x2m
- Grille et cadre en acier inoxydable AISI 304
- 60 mm de largeur
- Membrane d'imperméabilisation ISOL avec 1,5x2m

KIT WAY ROUND

mm		€		€		
330 x 60	BK4023601	130,00	BK4023602	150,00	1	10
400 x 60	BK4023611	135,00	BK4023612	155,00	1	10
500 x 60	BK4023621	140,00	BK4023622	160,00	1	10
600 x 60	BK4023631	145,00	BK4023632	165,00	1	10
700 x 60	BK4023641	155,00	BK4023642	175,00	1	10
800 x 60	BK4023651	165,00	BK4023652	185,00	1	10

Sifões de duche · Sifones de ducha
Shower siphon · Siphon de douche



360°

- Sifão de pavimento com rotação 360°
- Grelha em aço inox AISI 304
- Para aplicação em espaços de duche

- Sifón de suelo con rotación 360°
- Rejilla de acero inoxidable AISI 304
- Para uso en áreas de ducha

- Floor Siphon with 360° rotation
- AISI 304 Stainless steel grill and frame
- For use in shower areas

- Caniveau de douche avec rotation à 360°
- Grille et cadre en acier inoxydable AISI 304
- Pour une utilisation dans les zones de douche

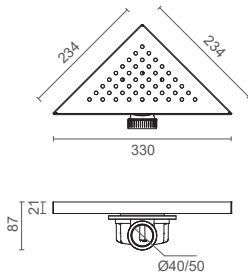

SQUARE

	REF.	mm	€
	BK4020711	230 x 230 Ø40/50mm	50,00
	BK4020712		80,00
	BK4020713		85,00
	BK4020714		85,00
	BK4020715		85,00



360°

- Sifão de pavimento com rotação 360°
- Grelha em aço inox AISI 304
- Para aplicação em espaços de duche

- Sifón de suelo con rotación 360°
- Rejilla de acero inoxidable AISI 304
- Para uso en áreas de ducha

- Floor Siphon with 360° rotation
- AISI 304 Stainless steel grill and frame
- For use in shower areas

- Caniveau de douche avec rotation à 360°
- Grille et cadre en acier inoxydable AISI 304
- Pour une utilisation dans les zones de douche

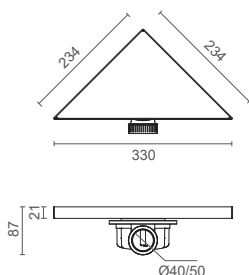

LINE

	REF.	mm	€
	BK4020811	230 x 230 Ø40/50mm	50,00
	BK4020812		80,00
	BK4020813		85,00
	BK4020814		85,00
	BK4020815		85,00





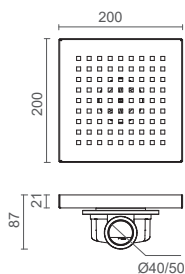

360°



- Sifão de pavimento com rotação 360°
- Grelha em aço inox AISI 304
- Para aplicação em espaços de duche
- Sifón de suelo con rotación 360°
- Rejilla de acero inoxidable AISI 304
- Para uso en áreas de ducha
- Floor Siphon with 360° rotation
- AISI 304 Stainless steel grill and frame
- For use in shower areas
- Caniveau de douche avec rotation à 360°
- Grille et cadre en acier inoxydable AISI 304
- Pour une utilisation dans les zones de douche

SQUARE

	REF.	mm	€
	BK4020701	200 x 200 Ø40/50mm	60,00
	BK4020702		90,00
	BK4020703		95,00
	BK4020704		95,00
	BK4020705		95,00



360°

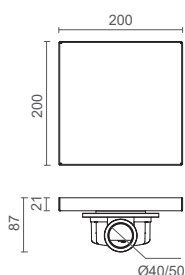

- Sifão de pavimento com rotação 360°
- Grelha em aço inox AISI 304
- Para aplicação em espaços de duche
- Sifón de suelo con rotación 360°
- Rejilla de acero inoxidable AISI 304
- Para uso en áreas de ducha
- Floor Siphon with 360° rotation
- AISI 304 Stainless steel grill and frame
- For use in shower areas
- Caniveau de douche avec rotation à 360°
- Grille et cadre en acier inoxydable AISI 304
- Pour une utilisation dans les zones de douche

LINE

	REF.	mm	€
	BK4020801	200 x 200 Ø40/50mm	60,00
	BK4020802		90,00
	BK4020803		95,00
	BK4020804		95,00
	BK4020805		95,00

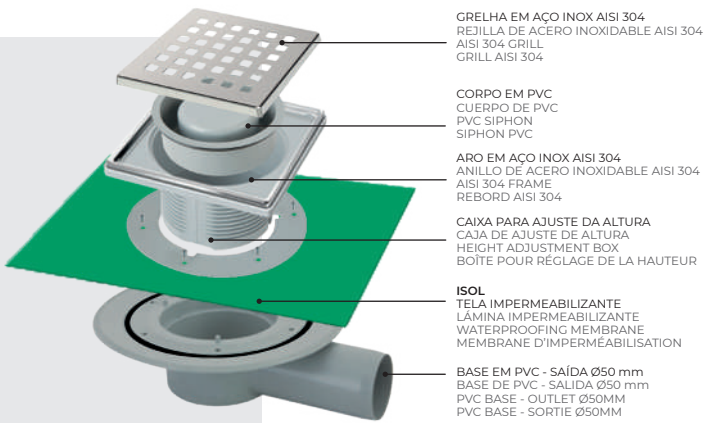
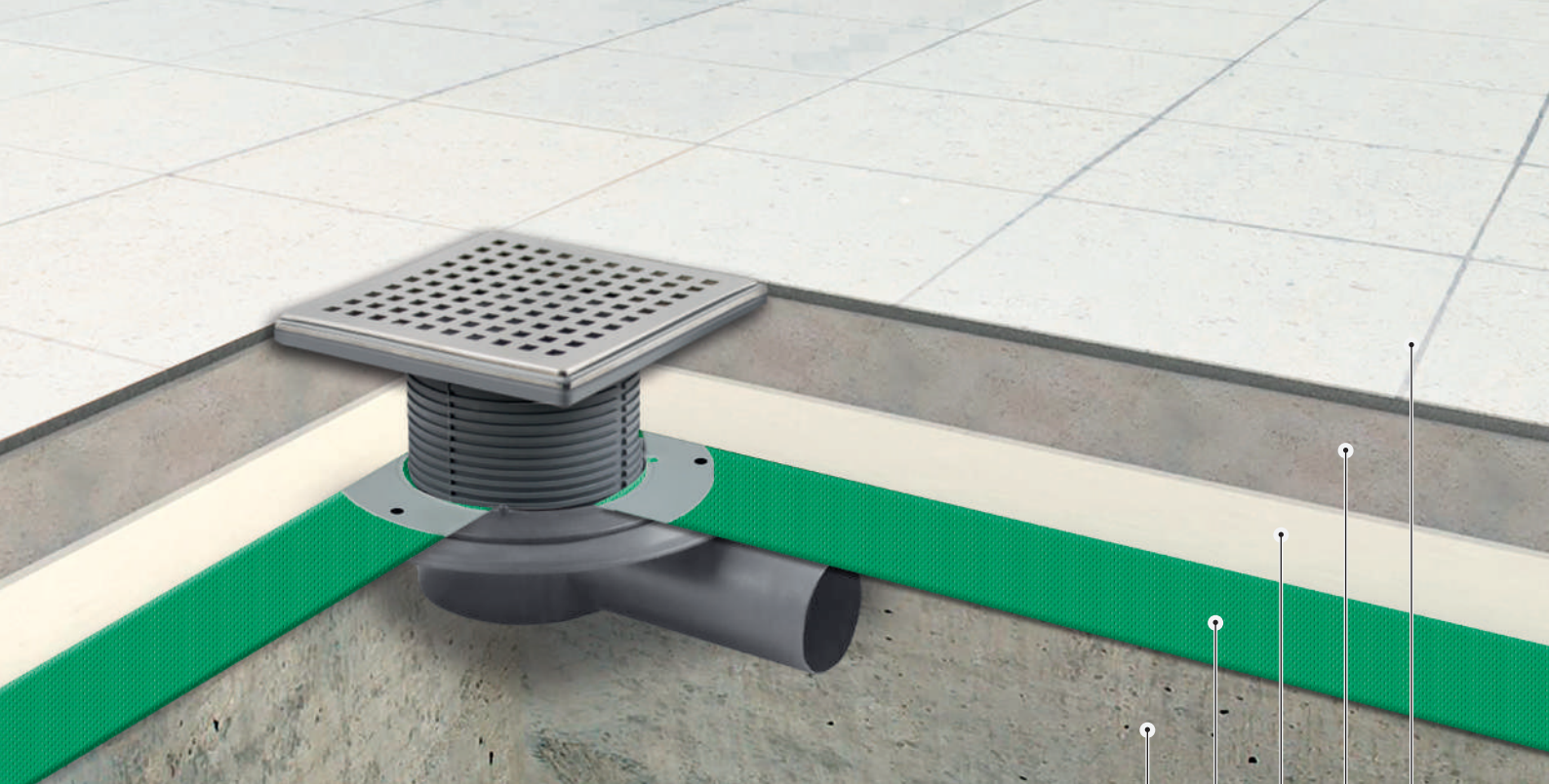

GRELHA EM AÇO INOX AISI 304
REJILLA DE ACERO INOXIDABLE AISI 304
GRILL AISI 304

CORPO EM PVC
CUERPO DE PVC
PVC SIPHON
SIPHON PVC

ARO EM AÇO INOX AISI 304
ANILLO DE ACERO INOXIDABLE AISI 304
AISI 304 FRAME
REBORD AISI 304

CAIXA PARA AJUSTE DA ALTURA
CAJA DE AJUSTE DE ALTURA
HEIGHT ADJUSTMENT BOX
BOÎTE POUR RÉGLAGE DE LA HAUTEUR

ISOL
TELA IMPERMEABILIZANTE
LÁMINA IMPERMEABILIZANTE
WATERPROOFING MEMBRANE
MEMBRANE D'IMPERMÉABILISATION

BASE EM PVC - SAÍDA Ø50 mm
BASE DE PVC - SALIDA Ø50 mm
PVC BASE - OUTLET Ø50MM
PVC BASE - SORTIE Ø50MM

BETÃO
CUBIERTA DE HORMIGÓN
CONCRETE DECK
TABLIER EN BÉTON

ISOL
TELA IMPERMEABILIZANTE
LÁMINA IMPERMEABILIZANTE
WATERPROOFING MEMBRANE
MEMBRANE D'IMPERMÉABILISATION

MATERIAL DE ISOLAMENTO
MATERIAL DE AISLAMIENTO
INSULATION MATERIAL
MATÉRIEL D'ISOLATION

NIVELAMENTO COM ARGAMASSA
NIVELACIÓN CON MORTERO
AISI 304 GRILL
GRILL AISI 304

PAVIMENTO DE CERÂMICA
SUPERFICIE DE CERÁMICA
CERAMIC SURFACE
SURFACE CÉRAMIQUE

**ALTURA AJUSTÁVEL
SAÍDA ORIENTÁVEL**

ALTURA AJUSTABLE
SALIDA ORIENTABLE
ADJUSTABLE HEIGHT/
ORIENTABLE OUTLET
RÉGLABLE EN HAUTEUR/
SORTIE ORIENTABLE



- Sifão de pavimento com grelha em aço inox AISI 304
- Altura ajustável / saída orientável
- Indicado para isolamento e impermeabilização da água
- Com anti-retorno de odores
- Tela Impermeabilizante ISOL com 1,5 x 2m

- Sifón de suelo con rejilla en acero inoxidable AISI 304
- Altura ajustable / Salida orientable
- Indicado para aislamiento y sellado
- Sistema antiolores
- Lámina Impermeabilizante ISOL con 1,5 x 2m

- Floor Siphon with AISI 304 Stainless grill
- Adjustable height / orientable outlet
- Indicated for isolation and sealing
- Anti-odor system
- ISOL Waterproofing Membrane with 1,5x2m

- Caniveaux de douche avec grill en acier inoxydable AISI 304
- Réglable en hauteur / sortie orientable
- Indiqué pour isolement et scellage
- Système anti-odeurs
- Membrane d'Imperméabilisation avec 1,5x2m

KIT SQUARE

Sifão ajustável com tela impermeabilizante
Sifón ajustable con lámina impermeabilizante
Sjustable siphon with waterproofing membrane
Siphon réglable avec membrane d'imperméabilisation

REF.		☞	☞	€
BK4021000	100 x 100 x Ø50mm	1	6	58,30
BK4021010	150 x 150 x Ø50mm	1	6	65,20



Sifões de pavimento · Sifones de suelo
Floor siphon · Siphon de sol



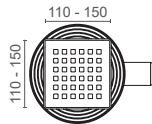
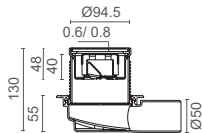

- Sifão de pavimento com grelha em aço inox AISI 304
- Altura ajustável / saída orientável
- Indicado para isolamento e impermeabilização da água
- Com anti-retorno de odores
- Para aplicação em espaços de duche, varandas, terraços e/ou caves
- Aplicado à altura do pavimento



- Sifón de suelo con rejilla en acero inoxidable AISI 304
- Altura ajustable / salida orientable
- Indicado para aislamiento y sellado
- Sistema antiolores
- Para uso en áreas de duchas
- Aplicado a la altura del piso

- Floor Siphon with AISI 304 Stainless grill
- Adjustable height / orientable outlet
- Indicated for isolation and sealing
- Anti-odor system
- For use in shower areas
- Applied to floor height

- Siphon de sol avec grill en acier inoxydable AISI 304
- Réglable en hauteur / sortie orientable
- Indiqué pour isolement et scellage
- Système anti-odeurs
- Pour une utilisation dans les zones de douche
- Appliqué à la hauteur du sol

SQUARE

Sifão chão horizontal
Sifón horizontal de suelo
Horizontal floor siphon
Siphon horizontale plancher

REF.				€
BK4020200	110 x 110 x Ø50 mm	1	24	21,10
BK4020210	150 x 150 x Ø50 mm	1	24	28,80

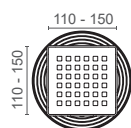
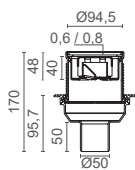

- Sifão de pavimento com grelha em aço inox AISI 304
- Altura ajustável
- Indicado para isolamento e impermeabilização da água
- Com anti-retorno de odores
- Para aplicação em espaços de duche, varandas, terraços e/ou caves
- Aplicado à altura do pavimento



- Sifón de suelo con rejilla en acero inoxidable AISI 304
- Altura ajustable
- Indicado para aislamiento y sellado
- Sistema antiolores
- Para uso en áreas de duchas, balcones, terrazas y/o bodegas
- Aplicado a la altura del piso

- Floor Siphon with AISI 304 Stainless grill
- Adjustable height
- Indicated for isolation and sealing
- Anti-odor system
- For use in shower areas, balconies, terraces and/or cellars
- Applied to floor height

- Siphon de sol avec grill en acier inoxydable AISI 304
- Réglable en hauteur
- Indiqué pour isolement et scellage
- Système anti-odeurs
- Pour une utilisation dans les zones de douche, balcon, terrasses et/ou les caves
- Appliqué à la hauteur du sol

SQUARE

Sifão chão vertical
Sifón vertical de suelo
Vertical floor siphon
Siphon verticale plancher

REF.	medidas · medidas measures · mesures			€
BK4020205	110 x 110 x Ø50 mm	1	24	21,10
BK4020215	150 x 150 x Ø50 mm	1	24	28,80

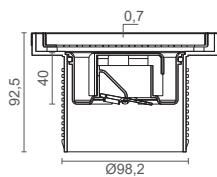
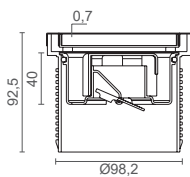
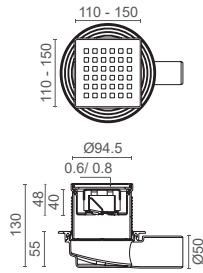

- Sifão de pavimento com aro em aço inox AISI 304
- Altura ajustável / saída orientável
- Com anti-retorno de odores
- Para aplicação em espaços de duche, varandas, terraços e/ou caves
- Para aplicação com cerâmica (máx. 7 mm)



- Sifón de suelo con rejilla en acero inoxidable AISI 304
- Altura ajustable / salida orientable
- Sistema antiolores
- Para uso en áreas de duchas, balcones, terrazas y/o bodegas
- Aplicado con baldosas

- Floor Siphon with AISI 304 Stainless grill
- Adjustable height / orientable outlet
- Anti-odor system
- For use in shower areas, balconies, terraces and/or cellars
- Applied to tiles

- Siphon de sol avec grill en acier inoxydable AISI 304
- Réglable en hauteur / sortie orientable
- Système anti-odeurs
- Pour une utilisation dans les zones de douche, balcon, terrasses et/ou les caves
- Appliqué avec carrelage

SQUARE

sifão chão horizontal p/ cerâmica
sifón horizontal de suelo para baldosas
horizontal floor siphon for tiles
siphon horizontale plancher pour carrelage

REF.				€
BK4020250	110 x 110 x Ø50 mm	1	24	22,90
BK4020260	150 x 150 x Ø50 mm	1	24	31,80

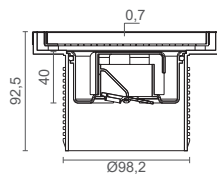
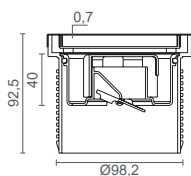
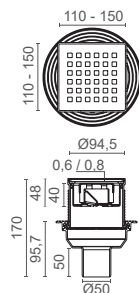

- Sifão de pavimento com aro em aço inox AISI 304
- Altura ajustável
- Com anti-retorno de odores
- Para aplicação em espaços de duche, varandas, terraços e/ou caves
- Para aplicação com cerâmica (máx. 7 mm)

- Sifón de suelo con rejilla en acero inoxidable AISI 304
- Altura ajustable
- Sistema antiolores
- Para uso en áreas de duchas, balcones, terrazas y/o bodegas
- Aplicado con baldosas

- Floor Siphon with AISI 304 Stainless grill
- Adjustable height
- Anti-odor system
- For use in shower areas, balconies, terraces and/or cellars
- Applied to tiles

- Siphon de sol avec grill en acier inoxydable AISI 304
- Réglable en hauteur
- Système anti-odeurs
- Pour une utilisation dans les zones de douche, balcon, terrasses et/ou les caves
- Appliqué avec carrelage

SQUARE

Sifão chão vertical p/ cerâmica
Sifón vertical de suelo para baldosas
Vertical floor siphon for tiles
Siphon verticale plancher pour carrelage

REF.	medidas · medidas measures · mesures			€
BK4020255	110 x 110 x Ø50 mm	1	24	22,90
BK4020265	150 x 150 x Ø50 mm	1	24	31,80

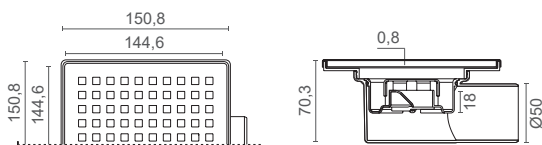

- Sifão de pavimento
- Grelha em aço inox AISI 304
- Saída orientável
- Com anti-retorno de odores
- Para aplicação em espaços de duche, varandas, terraços e/ou caves

- Sifón de suelo
- Rejilla en acero inoxidable AISI 304
- Salida orientable
- Sistema antiolores
- Para uso en áreas de duchas, balcones, terrazas y/o bodegas

- Floor Siphon
- AISI 304 Stainless grill
- Orientable outlet
- Anti-odor system
- For use in shower areas, balconies, terraces and/or cellars

- Siphon de sol
- Grill en acier inoxydable AISI 304
- Sortie orientable
- Système anti-odeurs
- Pour une utilisation dans les zones de douche, balcon, terrasses et/ou les caves

SQUARE

Sifão chão horizontal

Sifón horizontal de suelo para acabado

Finishing horizontal floor siphon

Siphon horizontale pour finition plancher

REF.				€
BK4020000	110 x 110 x Ø50 mm	1	32	8,60
BK4020001	110 x 110 x Ø50 mm	1	32	16,60
BK4020010	150 x 150 x Ø50 mm	1	20	11,20
BK4020011	150 x 150 x Ø50 mm	1	20	18,40

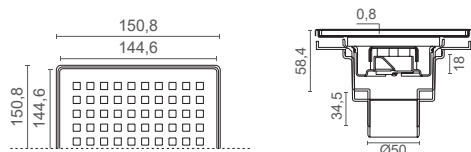

- Sifão de pavimento
- Grelha em aço inox AISI 304
- Com anti-retorno de odores
- Para aplicação em espaços de duche, varandas, terraços e/ou caves

- Sifón de suelo
- Rejilla en acero inoxidable AISI 304
- Sistema antiolores
- Para uso en áreas de duchas, balcones, terrazas y/o bodegas

- Floor Siphon
- AISI 304 Stainless grill
- Anti-odor system
- For use in shower areas, balconies, terraces and/or cellars

- Siphon de sol
- Grill en acier inoxydable AISI 304
- Système anti-odeurs
- Pour une utilisation dans les zones de douche, balcon, terrasses et/ou les caves

SQUARE

Sifão chão vertical

Sifón vertical de suelo

Vertical floor siphon

Siphon verticale plancher

REF.				€
BK4020100	110 x 110 x Ø50 mm	1	45	9,20
BK4020101	110 x 110 x Ø50 mm	1	45	17,40
BK4020110	150 x 150 x Ø50 mm	1	28	12,30
BK4020111	150 x 150 x Ø50 mm	1	28	19,30



ISOL

Tela impermeabilizante

Lámina impermeabilizante

Waterproofing membrane

Membrane d'imperméabilisation

- ISOL é uma Tela Impermeabilizante de 3 camadas composta por PP/ PU/ PP (polipropileno/ poliuretano/ polipropileno)
- Recomenda-se a sua aplicação para impermeabilização sob cerâmica de pavimento e revestimento, e/ou bases de duche em casas de banho
- É 100% à prova de água, flexível e fácil de aplicar
- Excelente aderência ao cimento
- Leve e simultaneamente bastante resistente
- Resistente e resiliente (conforme as normas EN12310 e EN12311)
- Resistente ao fogo (conforme norma EN11925)

- ISOL is 3-layers waterproofing membrane made of PP/PU/PP
- This installation is recommended for waterproofing under the floor and tiles and shower trays in bathrooms
- It is 100% waterproof, fl exible and easy to apply
- Excellent bonding to cement
- Lightweight and very strong at the same time
- Resistant and resilient (according to EN12310 and EN12311 standards)
- Fire resistant (according to the EN11925 standard)

- ISOL es una membrana impermeabilizante de 3 capas hecha de PP/PU/PP
- Se recomienda esta aplicación para impermeabilizaciones bajo suelo y revestimiento, y / o platos de ducha en baños
- Es 100% impermeable, fl exible y de aplicación sencilla
- Excelente adherencia al cemento
- Ligera y muy resistente al mismo tiempo
- Resistente y resiliente (de acuerdo con las normativas EN12310 y EN12311)
- Resistente al fuego (sde acuerdo con la normativa EN11925)

- ISOL est une membrane imperméable à 3 couches: PP/PU/PP
- Cette application est recommandée pour l'imperméabilisation sous le plancher et le revêtement et / ou les receveurs de douche dans les salles de bain
- Il est 100% imperméable à l'eau, fl exible et facile à appliquer
- Excellente adhérence au ciment
- Légère et très résistant à la fois
- Résistante et résiliente (selon les normes EN12310 et EN12311)
- Résistante au feu (selon la norme EN11925)

Tela impermeabilizante · Lámina impermeabilizante
Waterproofing membrane · Membrane d'imperméabilisation

REF.			€
BK4029000	1,5 x 5 m	1	85,40
BK4029010	1,5 x 10 m	1	151,40
BK4029030	1,5 x 30 m	1	410,60

Fita adesiva para calhas de duche · Cinta adhesiva para canaletas de ducha Adhesive tapa for shower drains · Ruban adhésive pour caniveaux de douche



Pode ser aplicado por colagem com cola de azulejo da classe C2, à base de epóxi ou massa de poliuretano (PU). Não pode ser aplicado com adesivos que contenham solventes. Recomenda-se a aplicação de massa de poliuretano na linha final das juntas.

Puede ser aplicado con cola de baldosas de la clase c2, a base de epóxi o masa de poliuretano (pu). No puede aplicarse con adhesivos que contienen solventes. Se recomienda la aplicación de masa de poliuretano en la línea final de las juntas.

It can be applied by bonding with c2 class tile adhesive, epoxy base dor pu based adhesive. It can't be applied with solvent-containing adhesives. It is recommended to apply pu mastic at the end line of the joints.

Il peut être appliqué par collage avec de la colle de carrelage de classe c2, à base d'époxy ou à base de pu. Il ne peut être appliquée avec des adhésifs contenant solvents. Il est recommandé d'appliquer le mastic pu à la ligne d'extrémité des joints.

REF.			€
BK4029550	3000 x 7,5cm	1	54,60

Válvulas de duche

Válvula de ducha
Shower valves
Valve de douche

PARA UMA DRENAGEM RÁPIDA E EFICAZ

As válvulas de duche Ctesi foram desenhadas para permitir um fácil acesso para manutenção, garantindo uma drenagem perfeita em qualquer tipo de instalação. O sistema de retenção de impurezas evita o arrastamento da sujidade para a rede de drenagem, enquanto contribui como anti-retorno dos odores.

PARA UN DRENAJE RÁPIDO Y EFECTIVO

Las válvulas de ducha Ctesi están diseñadas para permitir un fácil acceso para el mantenimiento, garantizando un drenaje perfecto en cualquier instalación. El sistema de retención de impurezas evita el arrastre de la suciedad en el sistema de drenaje, al tiempo que contribuye a un sistema antiolores.

FOR A QUICK AND EFFECTIVE DRAINAGE

Ctesi shower valves are designed to allow quick and easy access for maintenance, ensuring a perfect drainage in any installation. The impurities' retention system avoids the entrainment of dirt into the drainage system, while contributing to an anti-odor system.

POUR UN DRAINAGE RAPIDE ET EFFICACE

Les valves de douche Ctesi sont conçues pour permettre un accès facile pour la maintenance, en assurant un drainage parfait dans toute installation. Le système de retenue des impuretés évite l'entraînement de la saleté dans le réseau de drainage, tout en contribuant pour le non-reflux des odeurs.

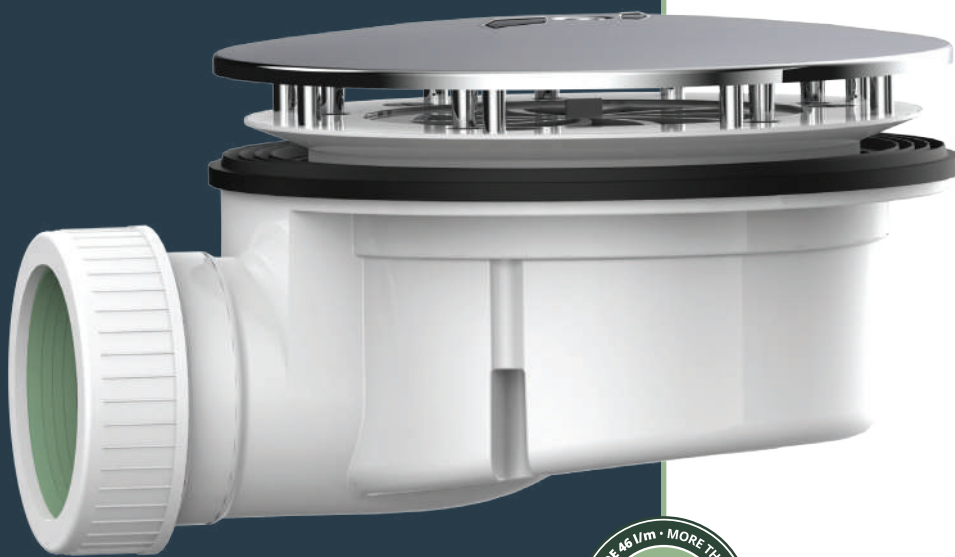

- Equipada com sifão de 20 mm extraível para limpeza;
- Tampa: Ø120 mm;
- Saída: Ø40 mm (interior) ou 1.1/2" (exterior);
- Entrada: Para furação Ø90 mm.

- Equipada con sifón de 20 mm extraíble para limpieza;
- Tapa: Ø120 mm;
- Salida: Ø40 mm (interior) o 1.1/2" (exterior);
- Entrada: Para agujero Ø90 mm.

- Equipped with a removable 20 mm siphon for cleanliness;
- Tapa: Ø120 mm;
- Outlet: Ø40 mm (interior) or 1.1/2" (exterior);
- Inlet: For furação Ø90 mm.

- Equipé d'un siphon amovible de 20 mm pour propreté;
- Tampa : Ø120 mm ;
- Sortie : Ø40 mm (intérieur) ou 1,1/2" (extérieur) ;
- Entrée : Pour furação Ø90 mm.

DONEK



Branca
Blanca
White
Blanc



Preta
Negro
Black
Noir

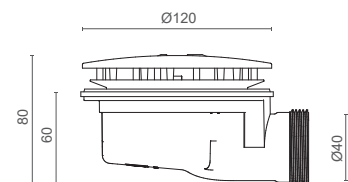

DONEK

Válvula de duche · Válvula de ducha
Shower waste · Vidage de douche

REF.					€
BK4000340	cromado · cromo chromed · chrome	1	48	768	21,10
BK4000342	branco · blanco white · blanc	1	48	768	19,10
BK4000341	preto mate · negro mate black matte · noir mate	1	48	768	28,10

DRAIN

Filtro "anti-cabelos"
Filtro "anti-pelo"
"Anti-hair" filter
Filtre "anti-cheveux"

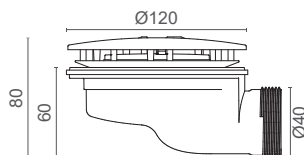
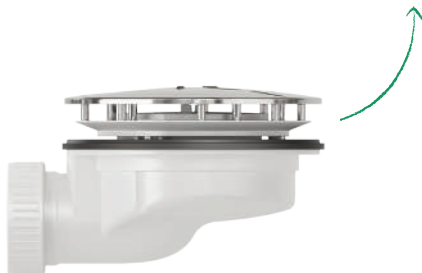

DRAIN

Válvula de duche · Válvula de ducha
Shower waste · Vidage de douche

REF.	mm					€
BK4000350	Ø120	cromado · cromo chromed · chrome	1	48	768	21,90
BK4000355	Ø120	branco · blanco white · blanc	1	48	768	19,90
BK4000357	Ø120	preto mate · negro mate black matte · noir mate	1	48	768	25,90

- Equipada com sistema anti-retorno (de águas e odores)
- Tampa: Ø120 mm;
- Drenagem Eficaz - EN-274 (> 24L/min)
- Saída: Ø40 mm (interior) ou 1.1/2" (exterior)
- Entrada: para furação Ø90 mm

- Equipadas con sistema de prevención (de aguas y olores)
- Tapa: Ø120 mm;
- Drenaje efectivo - EN-274 (> 24L/min)
- Salida: Ø40 mm (interior) o 1.1/2" (exterior)
- Entrada: para agujero Ø90 mm

- Equipped with anti-return system (water and odors)
- Tampa: Ø120 mm;
- Effective drainage - EN-274 (> 24L / min)
- Output: Ø40mm (inside) or 1"1/2 (outside)
- Input: For Ø90 drilling

- Equipé d'un système anti-retour (d'eau et d'odeurs)
- Tapa : Ø120 mm ;
- Drainage effi cace - EN-274 (> 24L / min)
- Sortie: Ø40mm (intérieur) ou 1"1/2 (extérieur)
- Entrée: Pour le forage Ø90

GYNOT

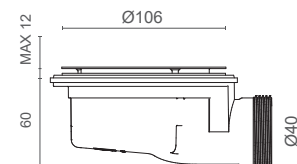

- Inclui aro em inox para fixação na base de duche;
- Equipada com sifão de 20 mm extraível para limpeza;
- Tampa: Ø120 mm;
- Saída: Ø40 mm (interior) ou 1,1/2" (exterior);
- Entrada: Para furação Ø90 mm.



- Incluye aro de acero inoxidable para fijación al plato de ducha;
- Equipado con un sifón extraíble de 20 mm para limpieza;
- Tapa: Ø120 mm;
- Salida: Ø40 mm (interior) o 1,1/2" (exterior);
- Entrada: Para agujero de Ø90 mm.

- Includes stainless steel ring for fixing to the shower tray;
- Equipped with a 20 mm removable siphon to cleaning;
- Cover: Ø120 mm;
- Outlet: Ø40 mm (inside) or 1,1/2" (outside);
- Inlet: For Ø90 mm hole.

- Comprend un anneau en acier inoxydable pour la fixation au receveur de douche ;
- Equipé d'un siphon amovible de 20 mm pour nettoyage;
- Couvercle : Ø120 mm ;
- Sortie : Ø40 mm (intérieur) ou 1,1/2" (extérieur) ;
- Entrée : Pour trou Ø90 mm.

GYNOT

Válvula de duche · Válvula de ducha
Shower waste · Vidage de douche

REF.					€
BK4000330	Ø106 mm	1	48	768	21,40

PETRA



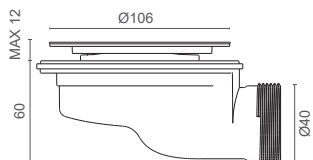

Filtro "anti-cabelos"
Filtro "anti-pelo"
"Anti-hair" filter
Filtre "anti-cheveux"



PETRA

Válvula de duche · Válvula de ducha
Shower waste · Vidage de douche

REF.					€
BK4000360	Ø106 mm	1	48	768	23,90



- Inclui aro em aço inox para fixação na base de duche
- Equipada com sistema anti-retorno (de águas e odores)
- Drenagem Eficaz - EN-274 (> 24L/min)
- Saída: Ø40 mm (Interior) ou 1.1/2" (exterior)
- Entrada: para furação Ø90 mm

- Incluye anillo de acero inoxidable para fijación al plato de ducha
- Equipadas con sistema de prevención (de aguas y olores)
- Drenaje efectivo - EN-274 (> 24L/min)
- Salida: Ø40 mm (interior) o 1.1/2" (exterior)
- Entrada: para agujero Ø90 mm

- Includes stainless steel rim for shower tray grip
- Equipped with anti-return system (water and odors)
- Effective drainage - EN-274 (> 24L / min)
- Output: Ø40mm (inside) or 1 1/2" (outside)
- Input: For Ø90 drilling

- Comprend une contour en acier inoxydable pour une meilleure prise sur le receveur de douche
- Equipé d'un système anti-retour (d'eau et d'odeurs)
- Drainage efficace - EN-274 (> 24L / min)
- Sortie: Ø40mm (intérieur) ou 1 1/2" (extérieur)
- Entrée: Pour le forage Ø90

Sifões lava-louças · Sifones fregadero
Dishwasher siphons · Siphons lave-vaisselle

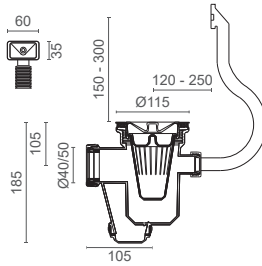

Sifão gordura c/ avisador
 sifón de grasa con rebosadero
 Grease siphon with overflow
 Siphon de graisse avec trop-plein

REF.				€
BK2012505	Ø115 x 40/50 - caixa	5	14	27,10

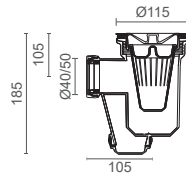

Sifão gordura
 Sifón de grasa
 Grease siphon
 Siphon de graisse

REF.				€
BK2012500	Ø115 x 40/50 - caixa	5	14	24,10

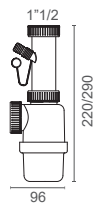

Simples s/ válvula
 Simple sin válvula
 Simple without valve
 Simple sans vidage

REF.				€
BK2012000	1.1/2"	5	70	4,20

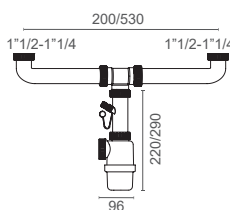

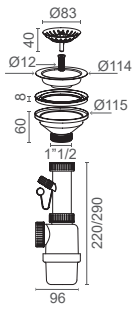

Duplo s/ válvulas
 Doble sin válvulas
 Dual without valves
 Double sans vidage

REF.				€
BK2012200	1.1/2"	5	25	7,90



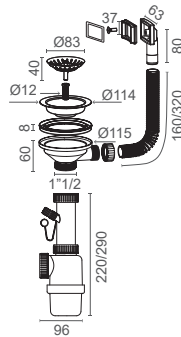

Simple c/ válvula cesto
Simple con válvula de cestilla
Simple with valve basket
Simple avec vidage à panier

REF.				€
BK2012030	1.1/2"	5	35	9,90



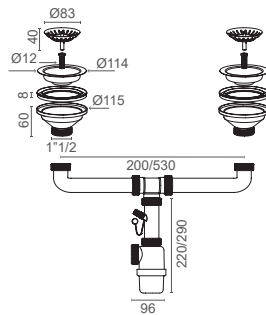

Simple c/ válvula cesto e avisador
Simple con válvula de cestilla y rebosadero
Simple with valve basket and overflow
Simple avec vidage panier et trop-plein

REF.				€
BK2012040	1.1/2"	5	30	11,30



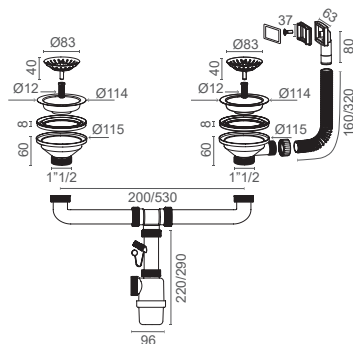

Duplo c/ válvulas cesto
Doble con válvula de cestilla
Dual with valve basket
Double avec vidage à panier

REF.				€
BK2012230	1.1/2"	5	15	19,30



Duplo c/ válvulas cesto e avisador
Doble con válvula de cestilla y rebosadero
Dual with valve basket and overflow
Double avec vidage panier et trop-plein

REF.				€
BK2012240	1.1/2"	5	14	20,70

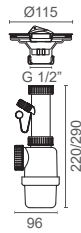

Simple com válvula
Simple con válvula
Simple with valve
Simple avec vidage

REF.				€
BK2012010	1.1/2"	5	50	7,20

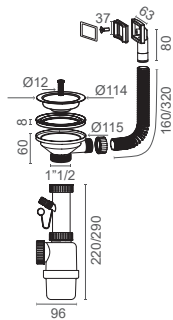

Simple com válvula e avisador
Simple con válvula y rebosadero
Simple with valve and overflow
Simple avec vidage et trop-plein

REF.				€
BK2012020	1.1/2"	5	36	11,00

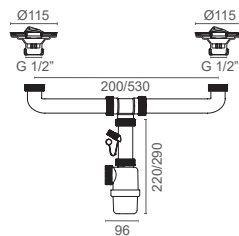

Duplo com válvulas
Doble con válvulas
Dual with valves
Double avec vidage

REF.				€
BK2012210	1.1/2"	5	18	13,90

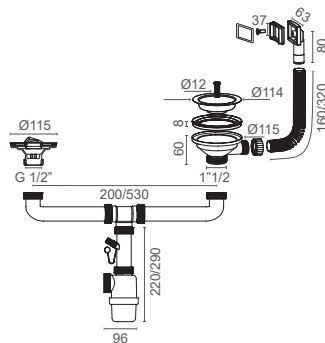

Duplo c/ válvulas e avisador
Doble con válvula y rebosadero
dual with valve and overflow
double avec vidage et trop-plein

REF.				€
BK2012220	1.1/2"	5	15	19,70

Sifões salva espaço lava-louça e lavatório

Sifones ahorro espacio fregadero y lavabo

Space saving siphons dishwasher and washbasins

Siphons gain de place lave-vaisselle et lavabo

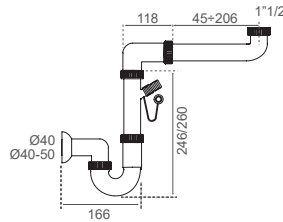

Sifão salva espaço simples lava-louça

Sifón ahorro de espacio simple fregadero

Simple space saving siphon for dishwasher

Siphon gain de place simple lave-vaisselle

REF.		10	80	€
BK2012400	1.1/2"	10	80	8,80

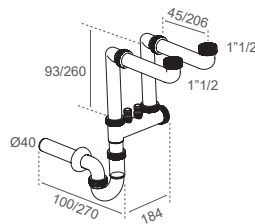
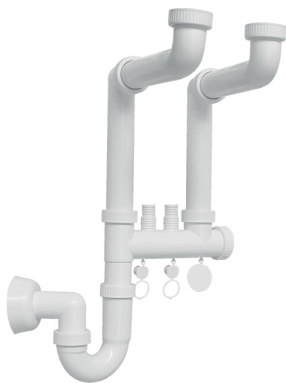

Sifão salva espaço duplo lava-louça

Sifón ahorro de espacio doble fregadero

Double space saving siphon for dishwasher

Siphon gain de place double lave-vaisselle

REF.		10	80	€
BK2012420	1.1/2"	10	80	12,30

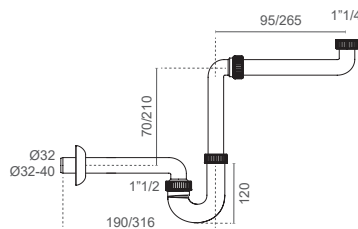

Sifão salva espaço lavatório

Sifón ahorro de espacio lavabo

Space saving siphon for washbasin

Siphon gain de place lavabo

REF.		10	80	€
BK2013005	1.1/4"	10	80	8,80

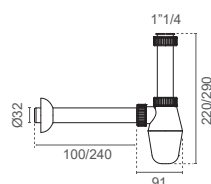

Sifão garrafa lavatório

Sifón botella de fregadero

Siphon bottle washbasin

Lavabo à bouteille à siphon

REF.		1	30	€
BK2013000	1.1/4"	1	30	4,60

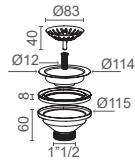

Válvula c/ cesto inox lava-louça
Valvula de cestilla fregadero
Valve basket washdisher
Vidage panier lave-vaisselle

REF.					€
BK2013210	Ø115	5	50		6,10

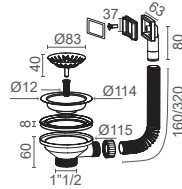

Válvula c/ cesto inox e avisador lava-louça
Valvula de cestilla y rebosadero fregadero
Valve basket and overflow washdisher
Vidage panier et trop-plein lave-vaisselle

REF.					€
BK2013220	Ø115	5	30		7,60



Válvula simples lava-louça
Valvula simple fregadero
Simple valve washdisher
Vidage simple lave-vaisselle

REF.					€
BK2013200	Ø115	5	70		2,98

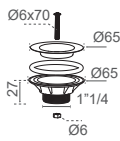

Válvula lavatório
Válvula de lavabo
Washbasin valve
Valve de lavabo

REF.					€
BK2013010	1.1/4"	5	130		2,05

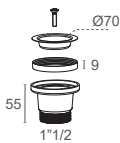

Válvula lavatório
Válvula de lavabo
Washbasin valve
Valve de lavabo

REF.					€
BK2013020	1.1/2"	5	85		2,75

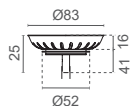

Cesto inox
Cestilla
Basket
Panier

REF.					€
BK2013290	Ø115	5	200		2,75

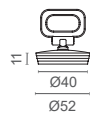

Taco

REF.					€
BK2013905	40mm	10	650		0,37
BK2013900	52mm	10	650		0,37

Acessórios máquina de lavar · Accesorios para lavadora

Washing machine accessories · Accessoires machine à laver

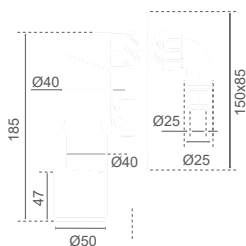

Sifão interior máquina de lavar
Sifón de empotrar para lavadora
Washing machine wall waste
Siphon intérieur machine à laver

REF.				€
BK2004000	Ø40 x 18/24 mm	5	50	6,95

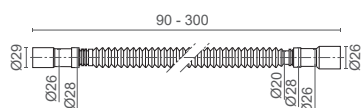

Tubo descarga extensível
Flexible lavadora
Washing machine flexible hose output
Tuyau flexible de sorti machine à laver

REF.				€
BK2004100	90-300 cm	1	100	2,60



Tubo descarga
Flexible de desagüe
Output hose
Tuyau de sorti

REF.				€
BK2004121	150 cm	1	50	1,95
BK2004122	200 cm	1	50	2,50
BK2004124	300 cm	1	50	3,20

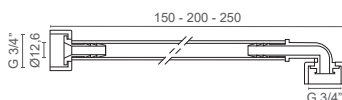

Bichas carga
Flexible de entrada
Input hose
Tuyau d'entrée

REF.				€
BK2004200	150 cm	1	50	4,25
BK2004202	200 cm	1	50	4,85
BK2004203	250 cm	1	50	5,60

Tampas para sifão · Cubiertas de sifón

Siphon covers plug · Couvercle pour siphon

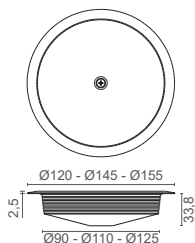

Tampa de expansão
Cubierta expansión
Expansion cover
Couvercle expansion

REF.				€
BK2010600	Ø90mm	1	60	5,40
BK2010601	Ø110mm	1	50	7,45
BK2010602	Ø125mm	1	30	8,70

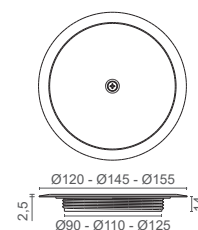

ABS aço inox polido AISI 304
ABS con acero inoxidable pulido AISI 304
ABS with polished AISI 304 stainless steel
ABS avec acier inox poli AISI 304

REF.				€
BK2010200	Ø90 mm	1	100	3,50
BK2010201	Ø110 mm	1	50	4,80
BK2010202	Ø125 mm	1	30	5,90

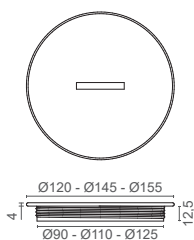

Tampa p/ sifão - abs cromado
Cubierta p/ sifón - abs cromo
Siphon cover - chromed abs
Couvercle pour siphon - abs chromé

REF.				€
BK2010000	Ø90 mm	1	250	2,80
BK2010001	Ø110 mm	1	200	3,00
BK2010002	Ø125 mm	1	150	3,80

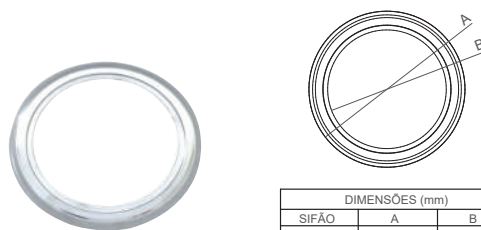

DIMENSÕES (mm)		
SIFÃO	A	B
Ø90 mm	Ø120.75	Ø91.75
Ø110 mm	Ø137.75	Ø108.75
Ø125 mm	Ø157.75	Ø128.75

Aros p/ sifão - abs
Marco para sifón - abs cromo
Cover flange - abs chromed
Cadre p/ siphon - abs chromé

REF.				€
BK2011000	Ø90 mm	1	250	1,70
BK2011001	Ø110 mm	1	200	1,90
BK2011002	Ø125 mm	1	160	2,10

Ventiladores · Rejilla ventilación Vent · Grille ventilation



Persiana branco
Rejilla blanco
White grid
Grille blanche

REF.				€
BK2008000	12 x 12 cm	10	25	0,84
BK2008005	15 x 15 cm	10	25	0,93
BK2008010	20 x 20 cm	10	50	1,80



Persiana branco
Rejilla blanco
White grid
Grille blanche

REF.				€
BK2008020	25 x 25 cm	10	30	2,60
BK2008030	30 x 30 cm	10	30	3,45
BK2008040	40 x 40 cm	10	15	6,65



Com regulador giratório branco
Regulador giratorio blanco
White rotating regulator
Régulateur rotatif blanc

REF.				€
BK2008200	12 x 12 cm	10	60	1,15
BK2008205	15 x 15 cm	10	50	1,33



Circular
Circular
Circular
Circulaire

REF.				€
BK2008300	Ø 12 cm	10	40	1,58
BK2008305	Ø 14 cm	10	25	1,92



Persiana rectangular branco
Rejilla blanco
White grid
Grille blanche

REF.				€
BK2008015	25 x 10 cm	-	10	1,75



Persiana rectangular branco
Rejilla blanco
White grid
Grille blanche

REF.				€
BK2008025	30 x 15 cm	10	30	2,30
BK2008035	40 x 20 cm	10	40	3,45

Tamos de sanita

Tapas de inodoro

Toilet seats

Abattants wc

A Ctesi apresenta-lhe uma variada gama de tamos de sanita em diferentes estilos e materiais como o polipropileno, MDF ou duraplast.

De fácil instalação, as ferragens utilizadas para estes tamos são de alta qualidade, permitindo uma simples instalação, mas também uma durabilidade comprovada.

As qualidades dos tamos de sanita Ctesi comprovam-se não apenas pelos seus materiais de primeira linha, mas também pela elegância e conforto que conferem à sua sanita.

Ctesi presenta una amplia gama de tapas de inodoro en diferentes estilos y materiales, como el polipropileno, el MDF o el duroplast.

Los herrajes de alta calidad utilizados para estas tapas permiten una instalación simple, pero también una durabilidad probada. La calidad de las tapas de inodoro Ctesi se evidencia no solo por sus materiales de primer nivel, sino también por su elegancia y comodidad.

Ctesi presents you a wide range of toilet seats made out in different styles and materials, such as polypropylene, MDF or duroplast.

The high quality ironwork used for these seats allows an easy installation but also a proven durability. The quality of Ctesi's toilet seats is proven not only by their top materials, but also by their elegance and comfort.

Ctesi vous présente une large gamme d'abattants wc dans différents styles et matériaux, tels que le polypropylène, le MDF ou le duroplast.

Le matériel de haute qualité utilisé pour ces abattants permet une installation simple mais aussi une durabilité éprouvée. La qualité des abattants wc Ctesi est attestée non seulement par leurs matériaux de premier ordre, mais aussi par leur élégance et leur confort.





Polipropileno · Polipropileno
Polypropylene · Polypropylène

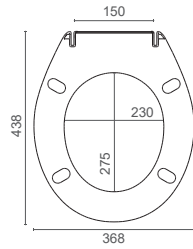

ÍLHAVO

REF.				€
BK3000000	branco · blanco white · blanc	6	12	9,00

Compatibilidades · Compatibilidad · Compatibility · Compatibilité
Europa, Munique, Estaco, Monterosa, Neoclássica, Lisboa, Algarve, Alvor

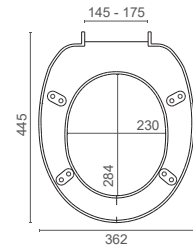

EQUADOR

REF.				€
BK3000020	branco · blanco white · blanc	5	10	15,00

Compatibilidades · Compatibilidad · Compatibility · Compatibilité
Apolo, alvor, Itália, Vitória, Monterosa, Neoclássica, Rubi, Imperial, Estaco, Munique

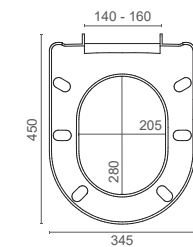

LUGO

REF.				€
BK3000040	branco · blanco white · blanc	5	10	17,00

Compatibilidades · Compatibilidad · Compatibility · Compatibilité
Água, Aveiro, Condor, Dama, Image, Eden, Meridian, Prestige, Regina, Thema

Versátil &
Resistente

Versátil y resistente
Versatil and resistant
Versatil et résistant

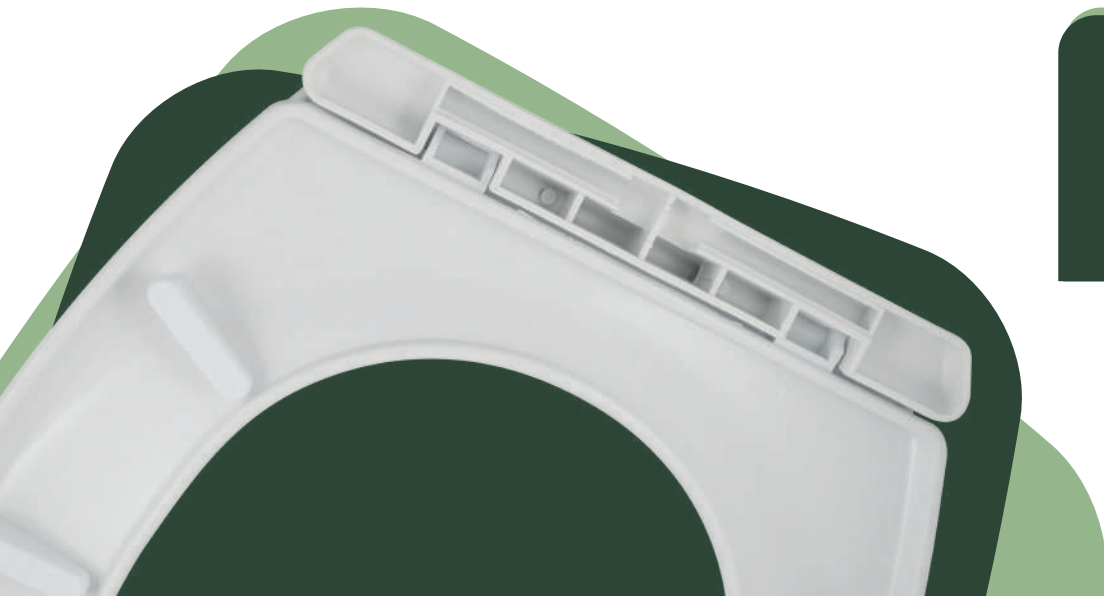

Polipropileno soft-close · Polipropileno soft-close
 Polypropylene soft-close · Polypropylène soft-close

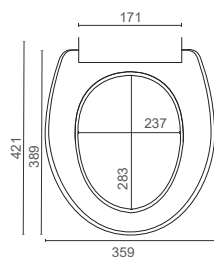

ESSIA

REF.				€
BK3001100	branco · blanco white · blanc	6	12	19,50

Compatibilidades · Compatibilidad · Compatibility · Compatibilité
 Inglês, Rubi, Estaco, Algarve, Apolo, Concha, Concreta, Itália, Lunar, Munique, Munique Plus, Monterosa, Madalena, Superbus, Sacavém, Vitória, Polo Zoom, Cetus, Europa, Helia, Lisboa

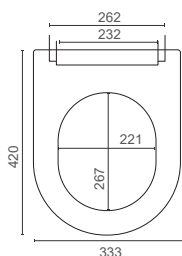

TEXA

REF.				€
BK3001120	branco · blanco white · blanc	6	12	19,50

Compatibilidades · Compatibilidad · Compatibility · Compatibilité
 Stylo, Meridian, Florença, Aveiro, Aqua, Condor, Image, Mimosa, Oceanus, Prestige, Projet, Eros, Sirius, Urby, Nexo

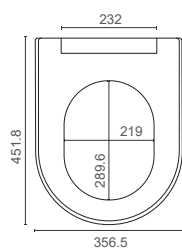

POLIS

REF.				€
BK3001140	branco · blanco white · blanc	6	12	19,50

Compatibilidades · Compatibilidad · Compatibility · Compatibilité
 Estoril, Alfa, Danubio, Dama, Renascença

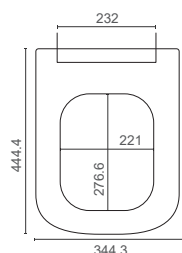

PURO

REF.				€
BK3001160	branco · blanco white · blanc	6	12	19,50

Compatibilidades · Compatibilidad · Compatibility · Compatibilité
 Gap



Duroplast soft-close

O Duroplast é um material de elevada resistência no qual se adicionam na sua construção partículas com propriedades anti-bacterianas, maximizando assim a limpeza e higiene em tempos de sanita que se apresentam com um aspecto brilhante ímpar.

The Duroplast is a high strength material in which is added in its construction particles with anti-bacterial properties, thereby maximizing cleaning and hygiene toilet seats while presenting with a unique glossy appearance.

El Duroplast es un material de alta resistencia al que se añaden en su producción partículas con propiedades antibacterianas, maximizando así la limpieza e higiene de las tapas de inodoro que presentan así una apariencia brillante única.

Le Duroplast est un matériau à haute résistance dans laquelle est ajouté dans sa construction des particules avec propriétés anti-bactériennes, maximisant ainsi le nettoyage et hygiène des toilettes en présentant un aspect brillant unique.



Fácil instalação

Fácil instalación
Easy installation
Installation facile

Fácil desmontagem

Fácil desmontaje
Easy disassembly
Démontage facile

Fecho amortecido

Cierre suave
Soft-close
Fermeture amortie

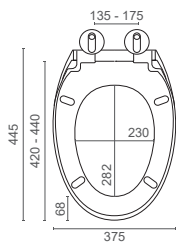

LETO

REF.				€
BK3004020	branco · blanco white · blanc	1	5	37,50

Compatibilidades · Compatibilidad · Compatibility · Compatibilité
Inglês, Rubi, Estaco, Algarve, Apolo, Concha, Concreta, Itália, Lunar, Munique, Munique Plus, Monterosa, Madalena, Superbus, Sacavém, Vitória, Polo Zoom, Cetus, Europa, Helia, Lisboa

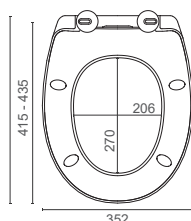



VITORIA

REF.				€
BK3004030	branco · blanco white · blanc	1	5	37,50

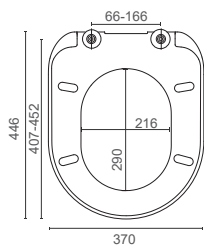





MEMPHIS

REF.				€
BK3004060	branco · blanco white · blanc	1	5	37,50

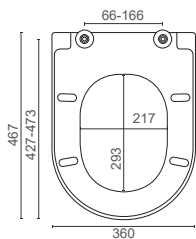
Compatibilidades · Compatibilidad · Compatibility · Compatibilit 
 Stylo, Meridian, Florena, Aveiro, Aqua, Condor, Image, Mimoso, Oceanus,
 Prestige, Projet, Eros, Sirius, Urby, Nexo





SOTIS

REF.				€
BK3004000	branco · blanco white · blanc	1	5	38,50

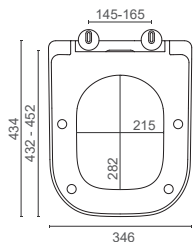
Compatibilidades · Compatibilidad · Compatibility · Compatibilit 
 Estoril, Alfa, Danubio, Dama, Renascena



GAP

REF.				€
BK3004050	branco · blanco white · blanc	1	5	41,10

N o compat vel com modelo de sanita suspensa compacta.
 No compatible con modelo de inodoro suspendido compacto.
 Not compatible with compact wall-hung toilet model.
 Non compatible avec mod le de toilette suspendue compacte.



Duroplast Slim com soft-close · Duroplast Slim con soft-close Duroplast Slim with soft-close · Duroplast Slim avec soft-close



MÁXIMO CONFORTO E ELEGÂNCIA

Assim, concentramos em apenas 21mm de espessura toda a resistência deste plástico reforçado com fibra e que termina com um acabamento brilhante e sublime. Com os tampos de sanita em Duroplast slim desfrute com o máximo conforto deste material antibacteriano num design de extrema elegância.

MAXIMUM COMFORT AND ELEGANCE

Thus, we concentrate in only 21mm of thickness all the resistance of this fiber-reinforced plastic and a brilliant and sublime finish. With Duroplast toilet tops, enjoy with the maximum comfort of this antibacterial material in an extremely elegant design.

MÁXIMO CONFORTO E ELEGÂNCIA

Así, concentramos en apenas 21mm de espesor toda la resistencia de este plástico reforzado con fibra y con un acabado brillante y sublime. Con las tapas de baño en Duroplast disfrutea con el máximo confort de este material antibacteriano en un diseño de extrema elegancia.

CONFORT ET ÉLÉGANCE MAXIMAUX

Ainsi, nous concentrons dans seulement 21 mm d'épaisseur toute la résistance de ce plastique renforcé de fibres et avec une finition brillante et sublime. Avec les abattants de toilette Duroplast, profitez de ce matériau antibactérien avec un maximum de confort dans un design extrêmement élégant.

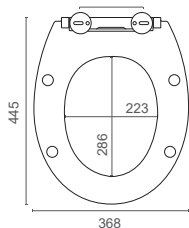

SUBLIME

REF.				€
BK3005000	branco · blanco white · blanc	1	5	44,10

Compatibilidades · Compatibilidad · Compatibility · Compatibilit 
Ingl s, Rubi, Estaco, Algarve, Apolo, Concha, Concreta, It lia, Lunar, Munique, Munique Plus, Monterosa, Madalena, Superbus, Sacav m, Vit ria, Polo Zoom, Cetus, Europa, Helia, Lisboa

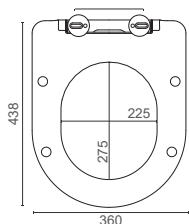

THIN

REF.				€
BK3005020	branco · blanco white · blanc	1	5	44,10

Compatibilidades · Compatibilidad · Compatibility · Compatibilit 
Regina, Atlanta, Stylo, Meridian, Floren a, Alfa, Alfa Plus, Nexo, Aveiro, Aqua, Condor, Dama, Image, Fade, Mimosa, Oceanus, Prestige, Danubio, Estoril, Elegance, Thema, Projet, Eros, Sirius, Urby



MDF

PERSONALIZAÇÃO

Os tampos de sanita em MDF Ctesi são fabricados à medida das suas necessidades e por isso adaptam-se a qualquer modelo de sanita.

CUSTOMIZATION

Ctesi MDF or marine plywood toilet tops are manufactured to fit your needs and therefore fit any toilet model.

PERSONALIZACIÓN

Las tapas de inodoro Ctesi MDF se fabrican a medida de tus necesidades y por tanto se adaptan a cualquier modelo de inodoro.

PERSONNALISATION

Les abattants de toilette Ctesi en MDF ou en contreplaqué marine sont fabriqués en fonction de vos besoins et convient donc à tout modèle de toilette.

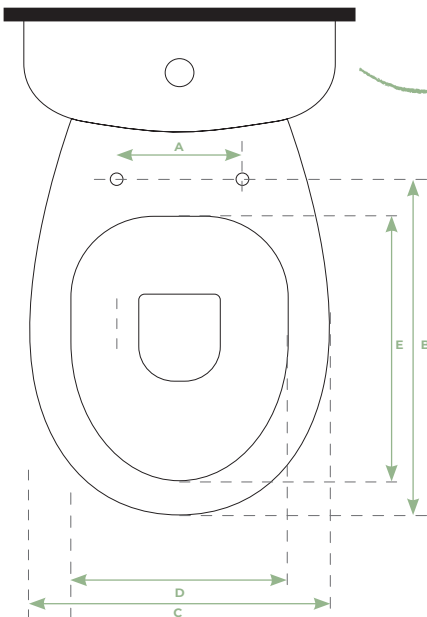

Se não sabe qual é o modelo exato da sua sanita, envie-nos uma foto e nós indicaremos qual o tampo adequado. É importante que nos envie as **medidas da sanita** para que a tampa se adapte perfeitamente à sua casa de banho.

Si no sabes el modelo exacto de tu inodoro envíanos una foto y te diremos cuál es la tapa adecuada. Es importante que nos envíes las **medidas del inodoro** para que el asiento encaje perfectamente en tu baño.

If you do not know your toilet's exact model, send us a photo and we will tell you the appropriate size. It is important that you send us the **toilet's measurements** so that the lid adapts perfectly to your bathroom.

Si vous ne connaissez pas le modèle exact de votre toilette, envoyez-nous une photo et nous vous indiquerons la taille appropriée. Il est important que vous nous envoyiez les **dimensions de votre toilette** pour que le couvercle s'adapte parfaitement à votre salle de bain.

LEGENDA · LEYENDA

- A** - Distância entre os centros das furações
- B** - Distância entre o centro das furações da sanita até à parte frontal
- C** - Largura máxima
- D** - Largura interior
- E** - Profundidade interior

- A** - Distancia entre los centros de los orificios
- B** - Distancia entre el centro de los orificios del inodoro y el frente
- C** - Ancho máximo
- D** - Ancho interior
- E** - Profundidad interior

LABEL · LÉGENDE

- A** - Distance between hole centers
- B** - Distance from toilet hole centers to the front
- C** - Maximum width
- D** - Interior width
- E** - Interior depth

- A** - Distance entre les centres des trous
- B** - Distance entre le centre des trous de la toilette et le devant
- C** - Largeur maximale
- D** - Largeur intérieure
- E** - Profondeur intérieure

MDF



dobradiça · bisagra
hinge · charnière



fixação · fijación
fixing · fixation

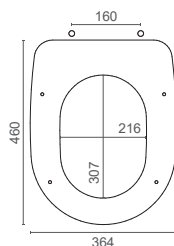
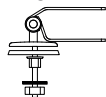

ZEUS

REF.				€
BK3018200	branco · blanco white · blanc	1	5	45,00

Compatibilidades · Compatibilidad · Compatibility · Compatibilité
Alfa, Dama, Meridian, Prestige



dobradiça · bisagra
hinge · charnière



fixação · fijación
fixing · fixation

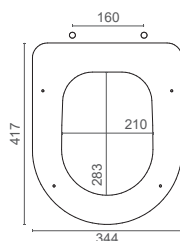
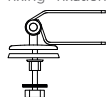

VÉNUS

REF.				€
BK3018000	branco · blanco white · blanc	1	5	45,00

Compatibilidades · Compatibilidad · Compatibility · Compatibilité
Água, Aveiro, Condor, Estoril, Image, Regina, Thema, Danúbio, Delta, Elegance, Oceanus, Florença, Jade



dobradiça · bisagra
hinge · charnière



fixação · fijación
fixing · fixation

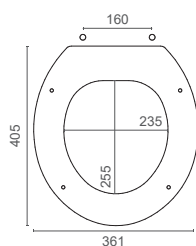
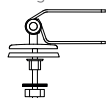

AFRODITE

REF.				€
BK3018600	branco · blanco white · blanc	1	5	45,00

Compatibilidades · Compatibilidad · Compatibility · Compatibilité
Europa, Itália, Munique, Estaco, Madalena, Apolo, Neoclássica, Monterosa, Luna, Vitória, Alvor, Lisboa, Algarve, Rubi



dobradiça
bisagra
hinge
charnière

fixação
fijación
fixing
fixation

SOFT-CLOSE:



dobradiça
bisagra
hinge
charnière

fixação
fijación
fixing
fixation

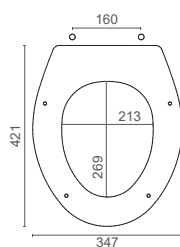

EUROPA

	REF.				€
SEM · SIN WITHOUT · SANS SOFT-CLOSE	BK3010000	branco blanco white	1	5	45,00
COM · CON WITH · AVEC SOFT-CLOSE	BK3010005	blanc	1	5	65,00



dobradiça
bisagra
hinge
charnière



fixação
fijación
fixing
fixation

SOFT-CLOSE:



dobradiça
bisagra
hinge
charnière



fixação
fijación
fixing
fixation

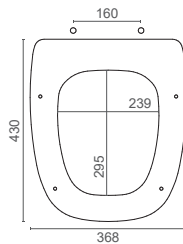

ENEZA

REF.			€
SEM · SIN WITHOUT · SANS SOFT-CLOSE	BK3010200	branco blanco white blanc	1 5 45,00
COM · CON WITH · AVEC SOFT-CLOSE	BK3010205		1 5 65,00



dobradiça
bisagra
hinge
charnière



fixação
fijación
fixing
fixation

SOFT-CLOSE:



dobradiça
bisagra
hinge
charnière



fixação
fijación
fixing
fixation

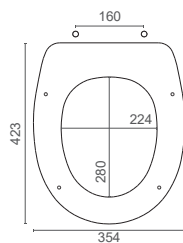

MUNIQUE

REF.			€
SEM · SIN WITHOUT · SANS SOFT-CLOSE	BK3010400	branco blanco white blanc	1 5 45,00
COM · CON WITH · AVEC SOFT-CLOSE	BK3010405		1 5 65,00



dobradiça
bisagra
hinge
charnière



fixação
fijación
fixing
fixation

SOFT-CLOSE:



dobradiça
bisagra
hinge
charnière



fixação
fijación
fixing
fixation

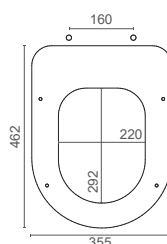

ALFA

REF.			€
SEM · SIN WITHOUT · SANS SOFT-CLOSE	BK3010600	branco blanco white blanc	1 5 45,00
COM · CON WITH · AVEC SOFT-CLOSE	BK3010605		1 5 65,00



dobradiça
bisagra
hinge
charnière



fixação
fijación
fixing
fixation

SOFT-CLOSE:



dobradiça
bisagra
hinge
charnière



fixação
fijación
fixing
fixation

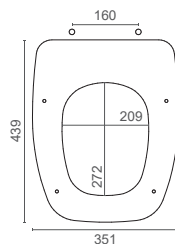

CONCORDE

REF.			€
SEM · SIN WITHOUT · SANS SOFT-CLOSE	BK3010800	branco blanco white blanc	1 5 45,00
COM · CON WITH · AVEC SOFT-CLOSE	BK3010805		1 5 65,00

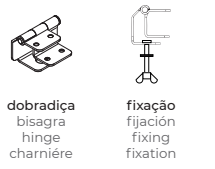

dobradiça
bisagra
hinge
charnière

fixação
fijación
fixing
fixation

SOFT-CLOSE:

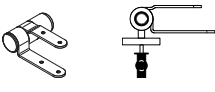

dobradiça
bisagra
hinge
charnière

fixação
fijación
fixing
fixation

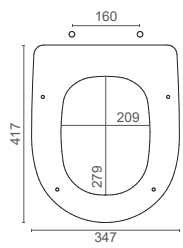

REGINA

SEM · SIN
WITHOUT · SANS
SOFT-CLOSE

COM · CON
WITH · AVEC
SOFT-CLOSE

REF.				€
BK3011200	branco blanco white blanc	1	5	45,00
BK3011205	branco blanco white blanc	1	5	65,00



dobradiça
bisagra
hinge
charnière

fixação
fijación
fixing
fixation

SOFT-CLOSE:

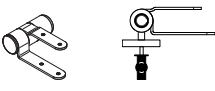

dobradiça
bisagra
hinge
charnière

fixação
fijación
fixing
fixation

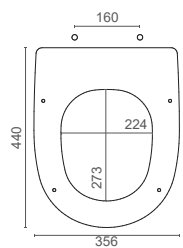

ESTORIL

SEM · SIN
WITHOUT · SANS
SOFT-CLOSE

COM · CON
WITH · AVEC
SOFT-CLOSE

REF.				€
BK3011400	branco blanco white blanc	1	5	45,00
BK3011405	branco blanco white blanc	1	5	65,00

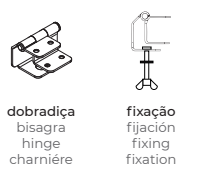

dobradiça
bisagra
hinge
charnière

fixação
fijación
fixing
fixation

SOFT-CLOSE:

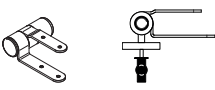

dobradiça
bisagra
hinge
charnière

fixação
fijación
fixing
fixation

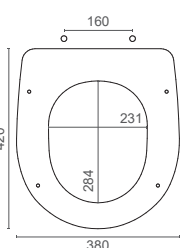

IMAGE

SEM · SIN
WITHOUT · SANS
SOFT-CLOSE

COM · CON
WITH · AVEC
SOFT-CLOSE

REF.				€
BK3012000	branco blanco white blanc	1	5	45,00
BK3012005	branco blanco white blanc	1	5	65,00

Tabela de preços geral para outros modelos · Lista general de precios para otros modelos
General price list for other models · Liste de prix générale pour les autres modèles

MDF Lacado · lacado · lacquered · laqué

Tampo de sanita Tapas de inodoro Toilet seats Abattants wc	Dobradiça normal · Bisagra normal Standard hinge · Charnière standard				Dobradiça soft-close · Bisagra soft-close Soft-close hinge · Charnière soft-close			
	Branco · Blanco White · Blanc	Pergamon	Cores · Colores Colors · Couleurs	RAL®	Branco · Blanco White · Blanc	Pergamon	Cores · Colores Colors · Couleurs	RAL®
sem traseira sin panel trasero no back panel sans panneau arrière	55,00€	60,00€	75,00€	100,00€	75,00€	80,00€	95,00€	120,00€
com traseira with panel trasero with back panel avec panneau arrière	60,00€	65,00€	80,00€	105,00€	-	-	-	-
up*	60,00€	65,00€	80,00€	105,00€	80,00€	85,00€	100,00€	125,00€
PMR / HANDICAP	55,00€	60,00€	75,00€	100,00€	75,00€	80,00€	95,00€	120,00€
infantil - sem traseira infantil - sin panel trasero children's - no back panel enfants - sans panneau arrière	55,00€	60,00€	75,00€	100,00€	75,00€	80,00€	95,00€	120,00€
infantil - com traseira infantil - with panel trasero children's - with back panel enfants - avec panneau arrière	60,00€	65,00€	80,00€	105,00€	-	-	-	-

Acessórios tampos de sanita · Accesorios tapas de inodoro Toilet seats accessories · Accessoires abattants wc



POLIPROPILENO

ILHAVO

REF.



€

BK3090000

1

2,80



POLIPROPILENO

EQUADOR / LUGO

REF.



€

BK3090020

1

4,30



DUROPLAST

DUROPLAST

REF.



€

BK3090260

1

14,20



MDF / CM

CONCORDE / IMAGE / VENEZA

REF.



€

BK3090310

1

9,40



MDF / CM

REGINA

REF.



€

BK3090320

1

9,40



MDF / CM

AFRODITE / VÉNIUS / ZEUS

REF.



€

BK3090300

1

9,40



MDF / CM

ALFA / ESTORIL

REF.



€

BK3090340

1

9,40

Válvulas de lavatório · Válvulas de lavabo

Washbasin waste valves · Bondes pour lavabo



Válvulas versáteis e duráveis, desenvolvidas para responder a diferentes necessidades dos espaços de banho.

Válvulas versátiles y duraderas, desarrolladas para responder a diferentes necesidades de los espacios de baño.

Versatile and durable valves, designed to meet the diverse needs of bathroom spaces.

Bondes polyvalentes et durables, conçues pour répondre aux différents besoins des espaces de bain.

Disponível nas cores · Disponible en colores
Available in colors · Disponible en couleurs:

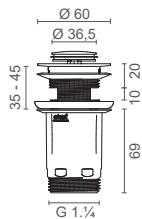

POLY

Com mola de plástico
Con resorte de plástico
With plastic spring
Avec ressort en plastique

REF.				€
BK4030500	1.1/4"	1	50	6,70

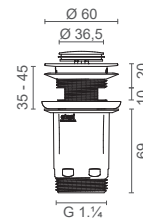

SEAL

Com mola de latão
Con resorte de latón
With brass spring
Avec ressort en laiton

REF.				€
BK4030000	1.1/4"	1	50	8,40

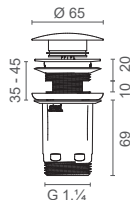

LOCK

REF.				€
BK4030100		1	50	10,60
BK4030110		1	50	11,80
BK4030105		1	50	17,10
BK4030120	1.1/4"	1	50	17,10
BK4030121		1	50	17,10
BK4030130		1	50	17,10
BK4030140		1	50	17,10

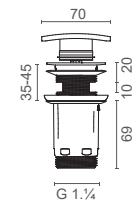

KARE

REF.				€
BK4030200		1	50	12,90
BK4030210		1	50	14,20
BK4030205		1	50	18,90
BK4030220	1.1/4"	1	50	18,90
BK4030221		1	50	18,90
BK4030230		1	50	18,90
BK4030240		1	50	18,90

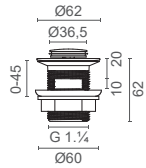

CORE

Com mola de plástico
 Con resorte de plástico
 With plastic spring
 Avec ressort en plastique

REF.				€
BK4031500	1,1/4"	1	50	6,80

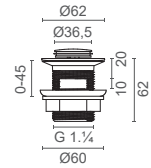

GASK

Com mola de latão
 Con resorte de latón
 With brass spring
 Avec ressort en laiton

REF.				€
BK4031000	1,1/4"	1	50	7,30

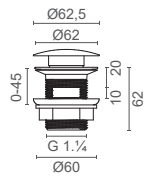

CLIP

REF.				€
BK4031100	1,1/4"	1	50	9,50

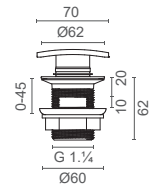

PLAN

REF.				€
BK4031200	1,1/4"	1	50	12,70

Válvulas de lavatório · Válvulas de lavabo Washbasin waste valves · Bondes pour lavabo

Tampa de cerâmica · tapa de cerámica · ceramic cover · couvercle en céramique

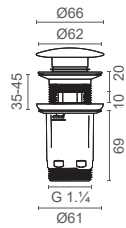

CERAX

REF.				€
BK4030300	1.1/4"	1	50	21,40

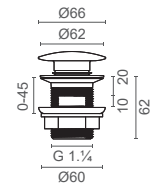

KERA

REF.				€
BK4031300	1.1/4"	1	50	20,40

Solid surface · Solid surface

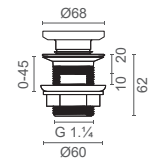

STON

REF.				€
BK4031400	1.1/4"	1	50	22,40

Descarga livre · Descarga libre · Free flow · Libre flux

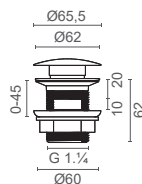

DRIP

REF.				€
BK4032100	1.1/4"	1	50	9,50

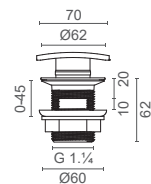

SPIL

REF.				€
BK4032200	1.1/4"	1	50	12,70

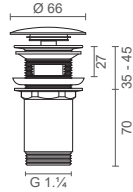

Tampão grande · Tapa grande
Big plug · Bouchon grand

REF.			€	
CT2100010	1	50	13,40	
CT2100012	1	50	15,40	
CT2100101	1	50	22,10	
CT2100102	1.1/4"	1	50	22,10
CT2100103	1	50	22,10	
CT2100108	1	50	22,10	
CT2100107	1	50	22,10	

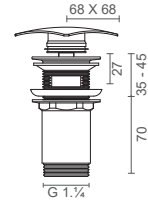

Tampão quadrado · Tapa cuadrada
Square plug · Bouchon carré

REF.			€	
CT2100020	1	50	16,60	
CT2100022	1	50	19,20	
CT2100121	1	50	28,70	
CT2100122	1.1/4"	1	50	28,70
CT2100123	1	50	28,70	
CT2100128	1	50	28,70	
CT2100127	1	50	28,70	

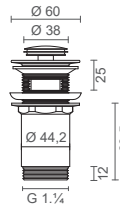

Tampão pequeno · Tapa pequeno
Small plug · Bouchon petit

REF.			€	
CT2100000	1.1/4"	10	100	11,30

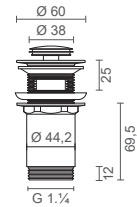

Tampão pequeno - aço inox · Tapa pequeña - acero inoxidable
Small plug - stainless steel · Bouchon petit - acier inoxydable

REF.			€	
CT2100002	1.1/4"	10	100	6,60

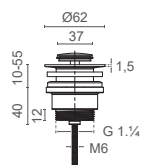

Com parafuso - tampão pequeno · Con tornillo - tapa pequeña
With screw - small plug · Avec vis - bouchon petit

REF.			€	
CT2100070	1.1/4"	1	50	11,70

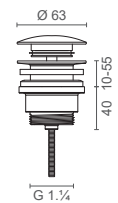

Com parafuso - tampão grande · Con tornillo - tapa grande
With screw - big plug · Avec vis - bouchon grand

REF.			€	
CT2100040	1.1/4"	1	50	13,70
CT2100045	1.1/4"	1	50	15,90

Sifões de lavatório · Sifones de lavabo
Washbasins traps · Siphons de lavabo

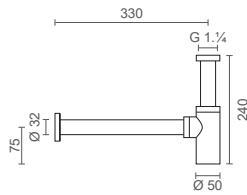

LINEA

REF.		☞	☞	€
CT2102000		1	20	35,00
CT2102002		1	20	51,40
CT2102201	tubo 30 cm tube 30 cm	1	20	78,00
CT2102202		1	20	78,00
CT2102203		1	20	78,00
CT2102208		1	20	78,00
CT2102207		1	20	78,00

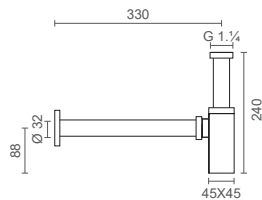

QUADRO

REF.		☞	☞	€
CT2102030		1	20	41,60
CT2102032		1	20	58,80
CT2102221	tubo 30 cm tube 30 cm	1	20	88,00
CT2102222		1	20	88,00
CT2102223		1	20	88,00
CT2102228		1	20	88,00
CT2102227		1	20	88,00

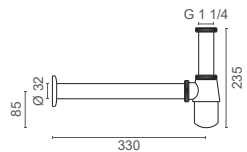

GARRAFA

REF.		☞	☞	€
CT2102101	tubo 30 cm tube 30 cm	1	20	23,50

Válvula de banheira · Válvula de bañera
Bathtub wastes · Bondes de baignoire

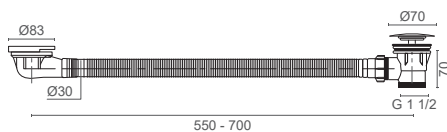

CLICK CLACK

REF.		☞	☞	€
CT2100250	1.1/2" x 40	1	20	29,50

Acessórios para sifões e válvulas · Accesorios para sifones y válvulas Siphons and valves accessories · Accessoires de siphons et vidage



Tubo flexível
Tubo flexible
Flexible pipe
Tuyau flexible

REF.				€
CT2102520	Ø32 x 30 cm	1	-	8,90



Tubo simples com aba
Tubo simple con borde
simple pipe with edge
Tuyau flexible avec rebord

REF.				€
CT2102541	Ø32 x 30 cm	1	-	6,20
CT2102543	Ø32 x 40 cm	1	-	6,90
CT2102544	Ø32 x 50 cm	1	-	8,60



Tampão para válvula click clack
Tapa de válvula
Valve cover
Couvercle de soupape

REF.				€
CT2260380	cromado cromo chrome chrome	1	-	2,05
CT2260381	cromado cromo chrome chrome	1	-	5,00



Tampão para válvula click clack
Tapa de válvula
Valve cover
Couvercle de soupape

REF.				€
CT2260382	cromado cromo chrome chrome	1	-	7,50



Vedante para tampão
Sello
Seal
Joint

REF.				€
CT2260390	click clack	10	-	0,39



Kit 3 vedantes para válvula click
Kit sello
Seal kit
Kit joint

REF.				€
CT2260398	click clack	1	-	1,85



Mola para válvula click clack
Resorte
Spring
Ressort

REF.			€
CT2260385	latão · latón brass · laiton	1	2,40

Bichas de chuveiro · Flexible de ducha Shower hose · Flexible de douche

SISTEMA ANTI-TORÇÃO

As bichas de chuveiro Giraflex da Ctesi são equipadas com sistema anti-torção, fazendo com que esta seja a escolha mais inteligente para quem pretende um duche agradável e pleno de conforto.

ANTI-TWIST SYSTEM

Ctesi's Giraflex shower nozzles are equipped with an anti-twist system, making this the smartest choice for anyone looking for a pleasant and comfortable shower.

SISTEMA ANTITORSIÓN

Los flexibles de ducha Giraflex de Ctesi están equipadas con un sistema antitorsión, lo que las convierte en la opción más inteligente para quienes desean una ducha agradable y confortable.

SYSTÈME ANTI-TORSION

Les buses de douche Giraflex de Ctesi sont équipées d'un système anti-torsion, ce qui en fait le choix le plus intelligent pour tous ceux qui recherchent un douche agréable et confortable.



GIRAFLEX

REF.			☞	☞	€
CT2202177	1,75 m	1	50		10,80

preto
negro
black
noir



GIRAFLEX

REF.			☞	☞	€
CT2202176	1,75 m	1	50		16,30

ouro
oro
gold
or



GIRAFLEX

REF.			☞	☞	€
CT2202178	1,75 m	1	50		16,30

ouro escovado
oro cepillado
brushed gold
or brossé



GIRAFLEX

REF.			☞	☞	€
CT2202181	1,75 m	1	50		16,80

brnze
brnze
brnze
brnze



GIRAFLEX

REF.			☞	☞	€
CT2202179	1,75 m	1	50		16,30

satinox



GIRAFLEX

REF.			☞	☞	€
CT2202180	1,75 m	1	50		16,80

grafite
grafito
graphite
graphite



GIRAFLEX

REF.			☞	☞	€
CT2202150	1,50 m	1	50		12,20
CT2202175	1,75 m	1	50		13,60
CT2202200	2,00 m	1	50		14,50



Bicha de chuveiro com cone
Flexible de ducha
Shower hose
Flexible de douche

REF.			☞	☞	€
CT2211150	1,50 m	1	50		6,20
CT2211175	1,75 m	1	50		7,00
CT2211200	2,00 m	1	50		7,40

☞ cromado · cromo
chrome · chrome



Bicha de chuveiro com cone
Flexible de ducha
Shower hose
Flexible de douche

REF.			☞	☞	€
CT2212500	1,70»2,20m	1	50		8,00

☞ cromado · cromo



LINEA

Rampa de chuveiro ABS · Barras ducha
Shower ramp · Ramp de douche

REF.		€
CT2234110		24,80



Torneiras esquadria · Válvulas de escuadra

Angle valves · Robinets d'équerre

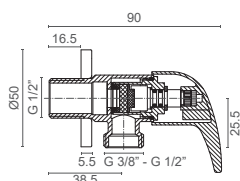

Monocomando
Monomando
Single lever mixer
Mitigeur

REF.				€
CT2262000	1/2" x 3/8"	5	100	8,20
CT2262001	1/2" x 1/2"	5	100	8,40

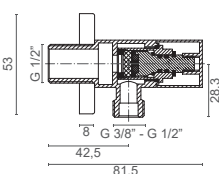

Cuadrada
Cuadrado
Square
Carré

	REF.				€
	CT2262040	1/2" x 3/8"	5	100	10,20
	CT2262041		5	100	11,30
	CT2262071		5	100	23,60
	CT2262072	1/2" x 1/2"	5	100	23,60
	CT2262075		5	100	16,50
	CT2262077		5	100	23,60
	CT2262078		5	100	23,60

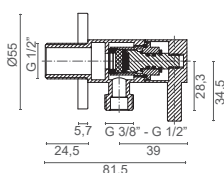

Cilíndrica
Cilíndrico
Cylindrical
Cylindrique

	REF.				€
	CT2262020	1/2" x 3/8"	5	100	8,20
	CT2262021		5	100	8,40
	CT2262051		5	100	16,60
	CT2262052	1/2" x 1/2"	5	100	16,60
	CT2262055		5	100	14,10
	CT2262057		5	100	16,60
	CT2262058		5	100	16,60

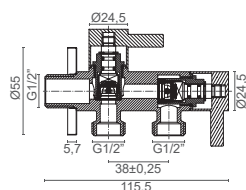

Cilíndrica dupla
Doble cilíndrico
Double cylindrical
Double cylindrique

REF.				€
CT2262220	1/2" x 1/2" x 1/2"	5	50	19,20

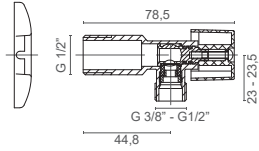

Normal

REF.				€
5032020	1/2" x 3/8"	20	100	3,10
5032021	1/2" x 1/2"	20	100	3,20

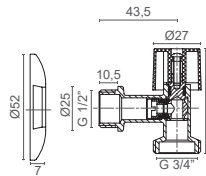

Máquina de lavar
Lavadora
Washing machine
Machine à laver

REF.				€
5032022	1/2" x 3/4"	10	100	3,30

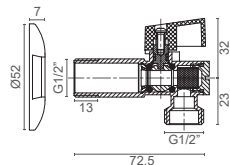

Longa c/ filtro
Larga con filtro
Long with filter
Longue avec filtre

REF.				€
5034401	1/2" x 3/8"	20	100	4,40
5034402	1/2" x 1/2"	20	100	4,60
5034403	1/2" x 3/4"	20	100	4,90



B

A

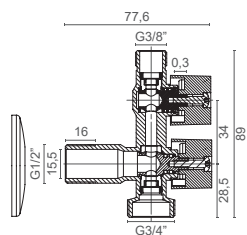

Dupla
Doble
Double
Paire

REF.				€
5032300	1/2" x 3/4" x 3/8"	10	50	8,90

A CONTROLO SAÍDA 3/4"
SALIDA 3/4"

B CONTROLO SAÍDA 3/8"
SALIDA 3/8"

Perlatores economizadores

Aireadores economizadores

Water saving aerators

Aérateurs économiseurs d'eau

Os perlatores são componentes imprescindíveis para a poupança de água. Previnem a acumulação dos pequenos detritos calcários e a limitação do caudal da água. Com a nossa gama de perlatores conseguirá uma redução de água até 50% nas torneiras da sua casa.

Los aireadores son componentes imprescindibles para el ahorro de agua. Previene la acumulación de los pequeños desechos calcáreos y permiten la limitación del caudal del agua. Con nuestra gama de aireadores conseguirás una reducción de agua hasta un 50% en los grifos de tu casa.

Faucet aerators are essential components for saving water. They prevent smallscale debris accumulation and allow water flow limitation. With our range of water faucet aerators, you'll get up to 50% water reduction in your home's taps.

Les aérateurs d'eau sont des composants essentiels pour économiser de l'eau. Ils empêchent l'accumulation de débris à petite échelle et permettent la limitation du débit d'eau. Avec notre gamme d'aérateurs hydro, vous obtiendrez une réduction d'eau jusqu'à 50% dans les robinets de votre maison.



Lavatório
Lavabo
Basin
Lavabo

REF.		10	250	€
CT1950200	M24 x 1	10	250	2,55

Consumo 6 l/min · Consumo 6 l/min
Consumption 6 l/min · Consommation 6 l/min



Banca
Fregadero
Sink
Évier

REF.		10	250	€
CT1950205	F22 x 1	10	250	2,55

Consumo 6 l/min · consumo 6 l/min
consumption 6 l/min · consommation 6 l/min



Kit economizador - interior perlator
Set economizador - aireador interior
Economizer kit - interior aerator
Ensemble économiseur - aérateur intérieur

REF.		10	250	€
CT1950230	-	10	250	3,25

Contém: 2 interiores economizadores
Contiene: 2 interiores economizadores
Contains: 2 interior economizers
Contient: 2 économiseurs intérieurs



Redutor chuveiro
Reductor de ducha
Shower reducer
Réducteur de douche

REF.		10	200	€
CT1950210	1/2"	10	200	5,15

Consumo 8 l/min · Consumo 8 l/min
Consumption 8 l/min · Consommation 8 l/min



Kit economizador - completo
Set economizador completo
Complete economizer kit
Ensemble économiseur complet

REF.		6	144	€
CT1950225	-	6	144	11,30

Contém: 2 perlatores economizadores lavatório; 1 perlator economizador banca; 1 reductor chuveiro
Contiene: 2 eco interior lavabo+ 2 eco aireadores fregadero+ 1 reductor de ducha.
Contains: 2 basin interior eco. + 1 sink eco. aerator + 1 shower reducer
Contient: 2 éco intérieur lavabo + 1 aérateur eco évier + 1 réducteur de douche



Kit economizador - simples
Set economizador simple
Simple economizer kit
Ensemble économiseur simple

REF.		6	168	€
CT1950235	-	6	168	9,40

Contém: 3 interiores economizadores e 1 reductor para chuveiro
Contiene: 3 eco interiores + 1 reductor de ducha.
Contains: 3 interior eco + 1 shower reducer
Contient: 3 éco intérieur + 1 réducteur de douche

Perlatores · Aireadores Aerators · Aérateurs



Lavatório
Lavabo
Basin
Lavabo

REF.				€
CT1950000	M24 x1	10	1000	1,60
Consumo 14 l/min · Consumo 14 l/ min Consumption 14 l/min · Consommation 14 l/min				



Lavatório
Lavabo
Basin
Lavabo

REF.				€
CT1950080	M18 x1	10	-	1,70
CT1950090	M20 x1	10	-	1,95
Consumo 14 l/min · Consumo 14 l/ min Consumption 14 l/min · Consommation 14 l/min				



Banheira
Bañera
Bathtub
Baignoire

REF.				€
CT1950010	M28 x1	10	1000	2,40
Consumo 14 l/min · Consumo 14 l/ min Consumption 14 l/min · Consommation 14 l/min				



Banca
Fregadero
Sink
Évier

REF.				€
CT1950005	F22 x1	10		1,85
Consumo 14 l/min · Consumo 14 l/ min Consumption 14 l/min · Consommation 14 l/min				



Bidé
Bidé
Basin
Bidet

REF.				€
CT1950015	M22 x1	10	1000	6,10
Consumo 14 l/min · Consumo 14 l/ min Consumption 14 l/min · Consommation 14 l/min				



Perlator
Aireador
Aerator
Aérateur

REF.				€
CT1951250	F M16X1 HC	10		5,65
Consumo 14 l/min · Consumo 14 l/ min Consumption 14 l/min · Consommation 14 l/min				



Bica - rótula cromado
Caño cromo ajustable
Adjustable chrome spout
Bec chromé orientable

REF.				€
CT1950215	F22 · M24	6	150	4,10
Consumo 18 l/min · Consumo 18 l/ min Consumption 18 l/min · Consommation 18 l/min				



Bica - flexível cromado
Caño cromo flexible
Flexible chrome spout
Bec chromé flexible

REF.				€
CT1950220	F22 · M24	6	50	7,90
Consumo 12 l/min. artigo fornecido em blister. Consumo 12 l/ min. artículo suministrado en un blister.				



Perlator coin
Aireador coin
Aerator coin
Aérateur coin

REF.				€
CT1952000	M24X1 HC A	10	-	1,60



Perlator cache
Aireador cache
Aerator cache
Aérateur cache

REF.				€
CT1952100	HC JR A	10	-	6,30



Interior perlator c/ anilhas
Interior aireador
Aerator interior
Interieur aérateur

REF.				€
CT1950020	-	10	-	1,55



Perlator slim
Aireador slim
Aerator slim
Aérateur slim

REF.				€
CT1952200	M24X1	10	-	3,20

*Contém: 2 interiores para perlatores



Perlator rectangular
Aireador
Aerator
Aérateur

REF.				€
CT1952500	RC 24x6mm	10	-	22,00



Perlator rectangular
Aireador
Aerator
Aérateur

REF.				€
CT1952550	RC 32x8mm	10	-	23,50

Bicas · Caños
Spouts · Becs

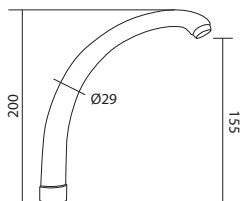

Bica superior cromada
Caño alto cromo
High spout chromed
Bec haut chrome

REF.				€
CT2218050	28 x 200	1	100	18,00

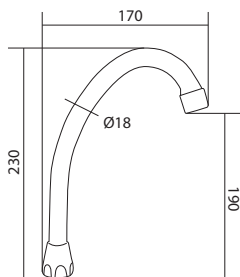

Bica "J" universal
caño "J" universal
"J" universal type spout
Bec universal "J"

REF.				€
CT2218010	Ø18 x 220	1	100	15,50

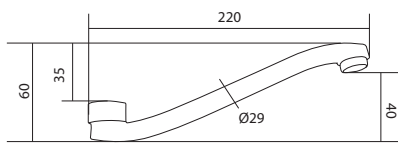

Bica inferior cromada
Caño bajo cromo
Low spout chromed
Bec inférieure chrome

REF.				€
CT2218055	28 x 260	1	100	18,00

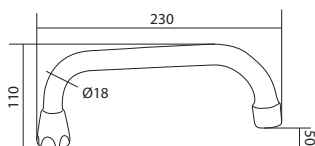

Bica "U" universal
Caño "U" universal
Universal "U" spout
Bec "U" universel

REF.				€
CT2218015	Ø18 x 220	1	100	15,50

Espelhos · Plafones Wall flange · Rosace

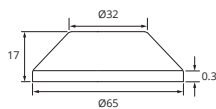

Espejo normal - latão
Plafone de pared - latón
Wall flange - brass
Rosace normal - laiton

REF.				€
CT2120000	Ø65 mm	2	10	1,75

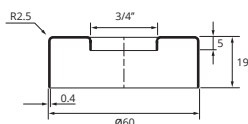
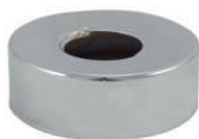

Espejo cilíndrico latão
Plafone cilíndrico - latón
Cylindrical wall flange - brass
Rosace cylindrique - laiton

REF.				€
CT2120020	Ø60 mm	2	10	2,70

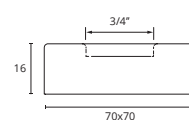

Espejo quadrado latão
Plafone cuadrado - latón
Square wall flange - brass
Rosace carré - laiton

REF.				€
CT2120030	70 x 70 mm	2	10	6,10

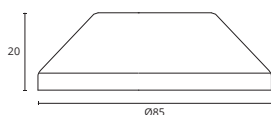

Espejo especial latão
Plafone especial - latón
Special wall flange - brass
Rosace spécial - laiton

REF.				€
CT2120011	Ø85 mm	2	10	4,90

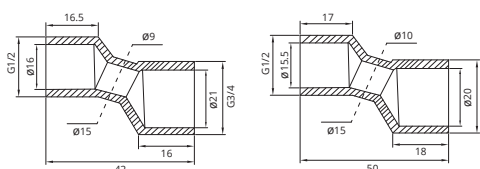

Excêntrico p/ misturadora normal
Unión excéntrica para mezclador
Normal eccentric union for mixer
Raccord normal "s" pour mitigeur

REF.				€
CT2120200	H42 mm*	2	10	2,55
CT2120201	H50 mm*	2	10	4,00

Excentricidade 9 mm // *1/2" x 3/4" · Excentricidad 9 mm
Eccentricity 9 mm · Excentricité 9 mm

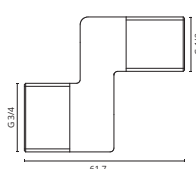

Excêntrico p/ misturadora especial
Unión excéntrica especial para mezclador
Special eccentric union for mixer
Raccord spécial "s" pour mitigeur

REF.				€
CT2120210	1/2" x 3/4"	2	10	7,90



Kit excêntrico H42 c/ espejo normal
Set excéntrico H42 con plafone
H42 eccentric kit with normal flange
Raccord ensemble H42 avec rosace normal

REF.				€
CT2120250	latão · latón brass · laiton	2	300	3,75



Kit excêntrico H50 c/ espejo cilíndrico
Set excéntrico H50 con plafone cilíndrico
H50 eccentric kit with cylindrical flange
Raccord ensemble H50 avec rosace cylindrique

REF.				€
CT2120260	latão · latón brass · laiton	2	200	5,50



Kit excêntrico H50 c/ espejo quadrado
Set excéntrico H50 con plafone cuadrado
H50 eccentric kit with square flange
Raccord ensemble H50 avec rosace carré

REF.				€
CT2120270	latão · latón brass · laiton	2	200	12,00

Ferragens · Herrajes grifos Tap fittings · Fixation robinet



Ferragens 2 parafusos
Herrajes 2 tornillos
Tap fixing set 2 screws
Esemble fixation 2 vis

REF.				€
CT2121810	M6 x 55 mm	1	150	3,20



Ferragens 1 parafuso pequeno
Herrajes 1 tornillo
Tap fixing set 1 screw
Esemble fixation 1 vis

REF.				€
CT2121800	M8 x 55 mm	1	150	4,80



Ferragens 1 parafuso médio
Herrajes 1 tornillo
Tap fixing set 1 screw
Esemble fixation 1 vis

REF.				€
CT2121820	M8 x 120 mm	1	100	6,00



Ferragens 1 parafuso grande
Herrajes 1 tornillo
Tap fixing set 1 screw
Esemble fixation 1 vis

REF.				€
CT2121830	M8 x 270 mm	1	100	9,00



Embelezador p/ cartucho
Tapa bajo p/ cartucho
Cartridge flange
Rosace cartouche

REF.				€
CT9020222	35 mm - Ø40 x 1,25	1	-	0,90
CT9020227	40 mm - Ø45 x 1,25	1	-	1,35



Porca aperto p/ cartucho
Tuerca de apriete
Tightening nut
Écrou de serrage

REF.				€
CT9020202	35 mm - M37 x 1,25	1	-	1,80
CT9020207	40 mm - M42 x 1,25	1	-	2,90

Castelos · Monturas

Brass cartridges · Tête à clapet

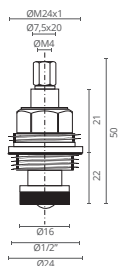

Castelo p/ passador c/ quadra
Montura
Cartridge
Tête à clapet

REF.				€
CT2121030	1/2" - 8 mm	10	200	5,05

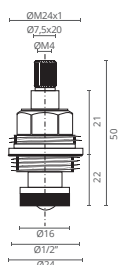

Castelo estriado curto
Montura estriado corto
Short valve cartridge
Tête à clapet court

REF.				€
CT2121000	1/2" - 8 mm	10	200	3,20

Amplitude de vedação até 22mm · Intervalo de sellado hasta 22mm
sealing breadth up to 22mm · intervalle d'étanchéité jusqu'à 22mm

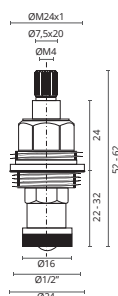

Castelo estriado especial
Montura estriado especial
Special valve cartridge
Tête à clapet spécial

REF.				€
CT2121020	1/2" - 8 mm	10	200	4,45

Amplitude de vedação até 32mm · Intervalo de sellado hasta 32mm
sealing breadth up to 32mm · intervalle d'étanchéité jusqu'à 32mm

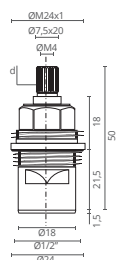

Castelo estriado cerâmico 1/4" volta
Montura disco cerâmico 1/4 vuelta
Ceramic disc headvalve 1/4" turn
Tête ceramique 1/4" tour

REF.				€
CT2121200	8 mm x 20 frio	10	200	5,10
CT2121201	8 mm x 20 quente	10	200	5,10

Cartuchos · Cartuchos Cartridges · Cartouches

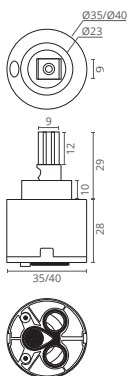

Cartucho universal · Cartucho universal Universal cartridges · Cartouches universel

REF.				€
CT2121410	Ø35 mm	5	80	5,40
CT2121420	Ø40 mm	5	80	5,40

- Ângulo máximo abertura: 25°
- Temperatura máxima: 90°C
- Pressão máxima: 35 Bar
- Vida esperada: 70.000 ciclos EN817
- Maximum opening angle: 25°
- Maximum temperature: 90°C
- Maximum pressure: 35 Bar
- Expected lifetime: 70.000 cycles EN817
- Ângulo máximo de abertura: 25°
- Temperatura máxima: 90°C
- Presión máxima: 35 Bar
- Vida útil estimada: 70.000 ciclos EN817
- Angle d'ouverture maximum: 25°
- Température maximale: 90°C
- Pression maximale: 35 bars
- Durée de vie prévue: 70 000 cycles EN817

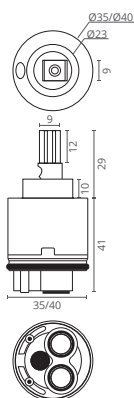

Cartucho univ. c/ distribuidor · Cartucho univ. con distribuidor Univ. cartridge with distributor · Cartouche univ. avec distributeur

REF.				€
CT2121411	Ø35 mm	5	80	6,60
CT2121421	Ø40 mm	5	80	6,60

- Ângulo máximo abertura: 25°
- Temperatura máxima: 90°C
- Pressão máxima: 35 Bar
- Vida esperada: 70.000 ciclos EN817
- Maximum opening angle: 25°
- Maximum temperature: 90°C
- Maximum pressure: 35 Bar
- Expected lifetime: 70.000 cycles EN817
- Ângulo máximo de abertura: 25°
- Temperatura máxima: 90°C
- Presión máxima: 35 Bar
- Vida útil estimada: 70.000 ciclos EN817
- Angle d'ouverture maximum: 25°
- Température maximale: 90°C
- Pression maximale: 35 bars
- Durée de vie prévue: 70 000 cycles EN817

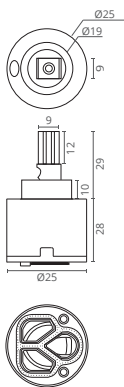

Cartucho ø25 · Cartucho ø25 ø25 cartridge · Cartouche ø25

REF.				€
CT2121400	Ø25 mm	5	-	5,60

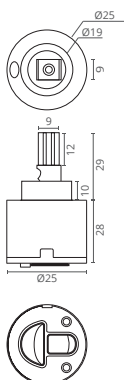

Cartucho ø25 - 1 água · Cartucho ø25 - 1 agua ø25 cartridge - 1 water · Cartouche ø25 - 1 voie

REF.				€
CT2121405	Ø25 mm	5	-	6,60

- Ângulo máximo abertura: 25°
- Temperatura máxima: 90°C
- Pressão máxima: 35 Bar
- Vida esperada: 70.000 ciclos EN817
- Maximum opening angle: 25°
- Maximum temperature: 90°C
- Maximum pressure: 35 Bar
- Expected lifetime: 70.000 cycles EN817
- Ângulo máximo de abertura: 25°
- Temperatura máxima: 90°C
- Presión máxima: 35 Bar
- Vida útil estimada: 70.000 ciclos EN817
- Angle d'ouverture maximum: 25°
- Température maximale: 90°C
- Pression maximale: 35 bars
- Durée de vie prévue: 70 000 cycles EN817

Kit de fixações louça sanitária · Kit de tornillos Sanitary fixings · Kit fixation sanitaires



Kit p/ lavatório
Kit para lavabo
Washbasin kit
Kit pour lavabo

REF.				€
0182001	cromado · cromo chromed · chrome	10	200	1,05



Kit p/ sanita / bidé
Kit para inodoro / bidé
Toilet / bidet kit
Kit pour cuvette/ bidet

REF.				€
0182002	cromado · cromo chromed · chrome	10	200	1,37



Kit p/ sanita / bidé
Kit para inodoro / bidé
Toilet / bidet kit
Kit pour cuvette/ bidet

REF.				€
0182003	aço inox · acero inoxidable stainless steel · acier inoxydable	10	250	3,18



Kit p/ sanita Roca
Kit para inodoro Roca / bidé
Roca toilet kit
Kit pour cuvette Roca

REF.				€
0182005	cromado · cromo chromed · chrome	10	250	1,82

Condições gerais · Condiciones generales de venta

General sale conditions · Conditions générales de vente

1

CATÁLOGO E ENCOMENDAS

CATÁLOGO
Y ÓRDENES
CATALOG
AND ORDERS
CATALOGUE
ET COMMANDES

A Barros & Moreira, S.A. e os seus clientes aceitam as seguintes condições gerais de venda a partir do momento em que a encomenda é formalizada:

- 1.1 Os preços aqui apresentados são meramente orientativos, reservando-se a Barros & Moreira a alterações dos mesmos sem aviso prévio. A estes preços acresce IVA, à taxa legal em vigor.
- 1.2 As informações existentes em catálogo são apresentadas apenas a título informativo, sendo possível efetuar alterações sem que exista um aviso prévio por parte da Barros & Moreira.
- 1.3 A confirmação de encomenda e prazo de entrega são sempre em função das disponibilidades de stock. Não é passível de qualquer indemnização a cliente, devido a atraso na entrega de encomendas.
- 1.4 Não é possível anulação, de encomendas que contenham produtos denominados especiais, em que, já se tenha iniciado o processo de fabricação.
- 1.5 A mercadoria permanece propriedade da Barros & Moreira, S.A., até à total liquidação da mesma.
- 1.6 Os produtos consideram-se entregues, após a sua descarga e confirmação por parte do cliente, através da sua assinatura no documento que se faz acompanhar. Caso a mercadoria seja entregue por transportadora é necessário, assinalar no talão de carga, todas as evidências físicas de como a mesma foi entregue, para que mais tarde, seja passível de reclamação. Não será considerada qualquer reclamação de "produto danificado por transporte" que não contenha anotação prévia no título de descarga.

Barros & Moreira S.A. y sus clientes aceptan las siguientes condiciones de venta a partir de la formalización del orden:

- 1.1 Los precios presentados en este catálogo son solamente informativos y Barros & Moreira se reserva el derecho de cambiarlos sin aviso previo. A estos precios se añade la tasa legal de IVA vigente.
- 1.2 La información en este catálogo es solamente informativa y Barros & Moreira puede realizar cambios sin aviso previo.
- 1.3 La confirmación del orden y la fecha de entrega dependen de la disponibilidad del stock. El cliente no está sujeto a ningún tipo de compensación cuando haya retrasos en la entrega de los pedidos.
- 1.4 No es posible cancelar ordenes que contengan productos considerados "especiales", donde el proceso de fabricación ya ha empezado.
- 1.5 La mercancía sigue perteneciendo a Barros & Moreira S.A. hasta su total liquidación.
- 1.6 Los productos se consideran entregados después de descargados y después de confirmar la recepción por el cliente, firmando el documento adjunto. En caso de que la mercancía sea entregada por un transportista, es necesario indicar en el recibo de carga toda la evidencia física de cómo ha llegado el producto, para que posteriormente pueda presentarse una reclamación. Cualquier reclamo del tipo "producto dañado por el transportista" que no contenga nota previa en el documento de carga, no se considerará.

Barros & Moreira S.A. and its customers accept the following terms and conditions from the moment the orders are closed:

- 1.1 The prices in this catalog are merely informative and Barros & Moreira reserves the right to change them without prior notice. The current VAT legal rate is added to these prices.
- 1.2 This catalog's information is presented for informational purposes only and changes may be made to it by Barros & Moreira without prior notice.
- 1.3 The order's confirmation and delivery date depends on the stock's availability. Order delivery delays do not require any compensation payment for the customer.
- 1.4 It is not possible to cancel orders that contain customized products, since the manufacturing process has already started.
- 1.5 The goods continue to belong to Barros & Moreira S.A. until their total payment.
- 1.6 The products are considered to be delivered after being unloaded and after the reception has been confirmed by the client by signing the delivery document. In case the goods are delivered by a carrier, it is necessary to indicate on the cargo receipt all the physical evidence of how the product has arrived, to present it in case of a future complaint. Any complaints for "product damaged by transport" that do not contain a previous note on the delivery receipt will not be considered.

Barros & Moreira, S.A. et leurs clients acceptent les conditions de vente suivantes, à partir du moment de la formalisation de l'ordre:

- 1.1 Les prix présentés dans ce catalogue ne sont qu'indicatifs et Barros & Moreira se réserve le droit de les modifier sans préavis. Le taux légal actuel de TVA est ajouté à ces prix.
- 1.2 Les informations de ce catalogue sont présentées à titre informatif uniquement et des modifications peuvent y être effectuées par Barros & Moreira sans préavis.
- 1.3 La confirmation de la commande et la date de livraison dépendent de la disponibilité du stock. Le client n'est soumis à aucun type de paiement supplémentaire en cas de retard dans la livraison des commandes.
- 1.4 Il n'est pas possible d'annuler des commandes contenant des produits considérés comme "spéciaux", lorsque le processus de fabrication a déjà commencé.
- 1.5 La marchandise continue d'appartenir à Barros & Moreira S.A. jusqu'à son paiement total.
- 1.6 Les produits sont considérés comme livrés après le déchargement et après la réception a été confirmée par le client en signant le document de livraison. Dans le cas où les produits sont livrés par un transporteur, il est nécessaire d'indiquer sur le récépissé de fret toutes les preuves matérielles de la façon dont le produit est arrivé, pour le présenter en cas de réclamation future. Toute réclamation pour «produit endommagé par le transporteur» qui ne contient pas une note préalable sur le récépissé de fret ne sera pas prise en compte.

2

GARANTIA GARANTÍA WARRANTY GARANTIE

2.1 Os produtos apresentados neste catálogo têm uma garantia de 3 anos, a partir da data da compra, salvo exceções indicadas e produto específico.

Como por exemplo:

Torneiras : 5 anos (à exceção dos modelos termostáticos e eletrónicos e complementos de torneiras – chuveiros, rampas e colunas de duche, bichas flexíveis, etc., que têm 3 anos)

Autoclismos Interiores: 10 anos (excluem-se desta garantia as peças de desgaste rápido).

2.2 As garantias incluem a total ou parcial substituição do produto, em caso de avaria, desde que, esta seja devido a defeito de fabrico. As garantias não cobrem situações decorrentes de utilização negligente, instalação incorreta, manutenção deficiente ou de motivos de causa maior.

2.3 O produto defeituoso deverá ser entregue com o certificado que o acompanha, devidamente preenchido, caso contrário considera-se excluída a possibilidade de reparação e/ou reposição do mesmo.

2.4 As reclamações devem ser endereçadas à Barros & Moreira por escrito, até a um prazo máximo, de 10 dias, a contar do dia de carga do produto.

2.5 Todas as reclamações carecem de análise e aprovação por parte do nosso departamento técnico. No caso de ser emitido um parecer positivo, a Barros & Moreira, será responsável pela reparação do artigo e só em último caso pela reposição de um novo ou do valor pago pelo mesmo.

2.6 São possíveis as devoluções de produto, desde que, até 10 dias após a compra e processo previamente aceite pela Barros & Moreira. Não são aceites devoluções de produtos especiais, assim como, produtos já aplicados e/ou danificados. Poderão ser imputados ao cliente custos, processuais, de embalagem e logísticos.

2

GARANTIA GARANTÍA WARRANTY GARANTIE

2.1 Los productos presentados en este catálogo tienen una garantía de 3 años a partir de la fecha de compra, salvo las excepciones indicadas y dependiendo de la especificidad del producto.

Como por ejemplo:

Grifería: 5 años (excepto modelos con acabado de Oro, Negro, Blanco o Satinox, así como modelos termostáticos, electrónicos y complementos de grifería: duchas, barras y columnas de ducha, flexibles, etc. que tienen 3 años de garantía).

Cisternas empotradas: 10 años (las piezas de desgaste rápido quedan excluidas de esta garantía).

2.2 La garantía incluye la sustitución total o parcial del producto en caso de avería, siempre que esta resulte de un defecto de fabricación. La garantía no cubre situaciones que resultan de un uso negligente, de una instalación o mantenimiento incorrectos, o de razones similares.

2.3 El producto con defecto deberá ser entregado y acompañado del respectivo certificado debidamente rellenado. De lo contrario, se excluye la posibilidad de reparar y/o reemplazar el producto.

2.4 Todas las reclamaciones deben dirigirse a Barros & Moreira en un plazo máximo de 14 días después de la fecha de carga del producto.

2.5 Todas las reclamaciones requieren la aprobación de nuestro Departamento Técnico. En caso de que este apruebe la reclamación, Barros & Moreira se encargará de reparar el producto y, en último recurso, se encargará de reemplazarlo o de devolver su valor.

2.6 Las devoluciones se aceptan siempre que sean hechas hasta 14 días después de la fecha de compra y siempre que aprobadas por Barros & Moreira. No se aceptan devoluciones de productos "especiales" y personalizados, así como productos ya ensamblados y/o dañados. Los costes de empaquetado y logísticos estarán a cargo del cliente.

2.1 The products in this catalog have a 3-year warranty from the date of purchase, except the ones indicated and depending on the product's specificity. Such as for example:

Taps: 5 years (except models with a Gold, Black, White or Satinox finish, as well as thermostatic and electronic models and tap accessories: showers, shower sliding rails and columns, flexibles, etc. that have a 3-year warranty).

Concealed flush cisterns: 10 years (the normal abrasion of wear parts is excluded from this warranty).

2.2 The warranty includes the product's total or partial replacement in case of failure that comes from a manufacturing defect. It does not cover situations that result from negligent use, improper installation or maintenance, or other similar reasons.

2.3 The damaged product must be delivered and accompanied by its duly completed certificate. Otherwise, the product will not be repaired and/or replaced.

2.4 All complaints must be addressed to Barros & Moreira within a maximum period of 14 days after the product's loading date.

2.5 All complaints require approval from our Technical Department. In case our Department approves the complaint, Barros & Moreira will be responsible for repairing the product or, as a last resort, for replacing it or returning the amount paid for it.

2.6 Returns are accepted as long as they are made up to 14 days from the purchase date and if approved by Barros & Moreira. Returns of customized products, as well as products that have already been assembled and / or damaged products, are not accepted. Packaging and logistics costs will be borne by the customer.

2.1 Les produits présentés dans ce catalogue bénéficient d'une garantie de 3 ans à compter de la date d'achat, sauf les exceptions indiquées et en fonction de la spécificité du produit. Comme par exemple:

Robineets: 5 ans (sauf les modèles avec une finition en Or, Noir, Blanc ou Satinox, ainsi que les modèles thermostatiques et électroniques et des accessoires de robinetterie: douches, barres et colonnes de douche, flexibles, etc. qui ont une garantie de 3 ans).

Réservoirs intérieurs: 10 ans (les pièces d'usure rapide sont exclues de cette garantie).

2.2 The warranty includes the product's total or partial replacement in case of failure that comes from a manufacturing defect. It does not cover situations that result from negligent use, improper installation or maintenance, or other similar reasons.

2.3 Le produit défectueux doit être livré et accompagné du certificat correspondant dûment complété. Dans le cas contraire, la possibilité de réparer et / ou de remplacer le produit est exclue.

2.4 Toute réclamation doit être adressée à Barros & Moreira dans un délai maximum de 14 jours après la date de chargement du produit.

2.5 Toutes les réclamations doivent être approuvées par notre Département Technique. Dans le cas où notre Département approuve la réclamation, Barros & Moreira sera responsable de la réparation du produit ou, en dernier recours, de son remplacement ou de restituer le montant que vous avez payé.

2.6 Les retours sont acceptés à condition qu'ils soient effectués jusqu'à 14 jours à compter de la date d'achat et s'ils sont approuvés par Barros & Moreira. Les retours de produits personnalisés, ainsi que les produits déjà assemblés et / ou endommagés, ne sont pas acceptés. Les frais d'emballage et de logistique seront à la charge du client.

3

JURISDIÇÃO JURISDICCIÓN JURISDICTION JURISDICTION

Em caso de Litígio, o foro competente é o da comarca das Caldas da Rainha.

En caso de litigio, el tribunal competente es el del Región de Caldas da Rainha.

Should a dispute arise hereof, the competent jurisdiction shall be the District Court of Caldas da Rainha.

En cas de litige, le tribunal compétent est celui de la circonscription de Caldas da Rainha.

4

ADVERTÊNCIAS ADVERTENCIAS WARNINGS AVERTISSEMENTS

Reservamo-nos ao direito de proceder a qualquer alteração, sem qualquer aviso prévio, nos preços, materiais e especificações descritas.

As medidas apresentadas são a título orientativo, assim como, as cores apresentadas neste catálogo poderão variar da realidade, devido a variações de impressão.

Nos reservamos el derecho de cambiar los precios, las especificaciones y materiales descritos sin previo aviso.

Las medidas presentadas son de carácter orientativo y los colores en este catálogo pueden variar de la realidad debido a las variaciones de impresión.

We have the right to make any changes to prices, materials and specifications without any prior notice.

The presented measures and information are for guidance and advisory only. The colours shown in this catalogue may differ from reality, due to printing issues.

Nous nous réservons le droit d'apporter des modifications sans préavis aux prix, matériaux et spécifications décrites.

Les mesures présentées le sont uniquement à titre indicatif, de même que les couleurs présentées dans ce catalogue peuvent avoir des variations quant au produit en raison des variations d'impression.

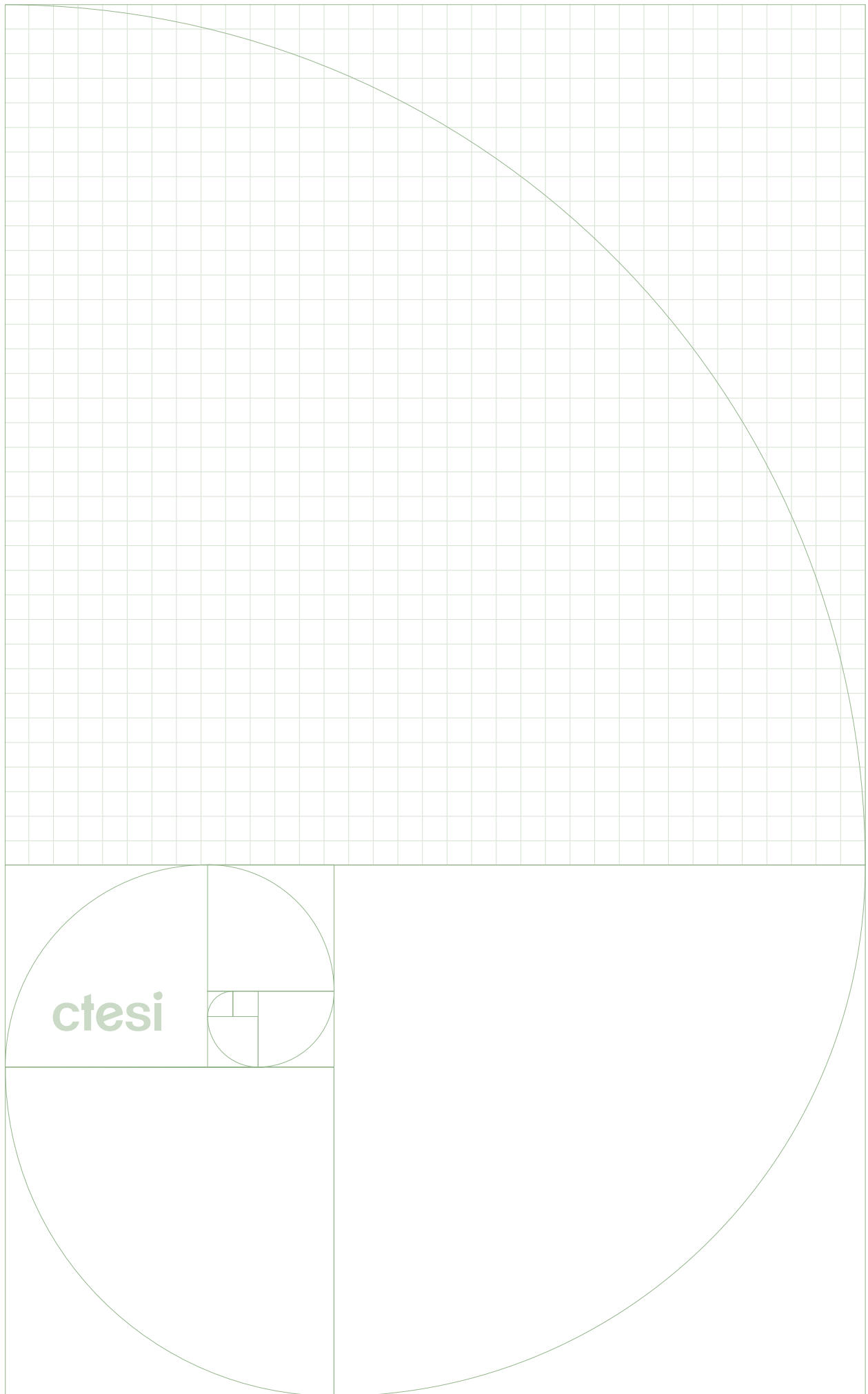

ctesi



ctesi

Barros & Moreira, SA

Rua Industrial, nº 8
Zon Industrial da Ponte Seca
2510-752 Gaeiras - Óbidos
Portugal

geral@barros-moreira.pt
www.ctesi.pt
Tel.: (+351) 262 837 230 || Fax: (+351) 262 837 231
Serviço de apoio pós venda **LINHA AZUL 808 203 870**